



# Design of floor structures for human induced vibrations

M. Feldmann, Ch. Heinemeyer, Chr. Butz, E. Caetano, A. Cunha, F. Galanti, A. Goldack, O. Hechler, S. Hicks, A. Keil, M. Lukic, R. Obiala, M. Schlaich, G. Sedlacek, A. Smith, P. Waarts

Background document in support to the implementation, harmonization and further development of the Eurocodes



## Joint Report

Prepared under the JRC – ECCS cooperation agreement for the evolution of Eurocode 3  
(programme of CEN / TC 250)

Editors: G. Sedlacek, Ch. Heinemeyer, Chr. Butz

EUR 24084 EN - 2009





# Design of floor structures for human induced vibrations

M. Feldmann, Ch. Heinemeyer, Chr. Butz, E. Caetano, A. Cunha, F. Galanti, A. Goldack, O. Hechler, S. Hicks, A. Keil, M. Lukic, R. Obiala, M. Schlaich, G. Sedlacek, A. Smith, P. Waarts

Background document in support to the implementation, harmonization and further development of the Eurocodes



## Joint Report

Prepared under the JRC – ECCS cooperation agreement for the evolution of Eurocode 3  
(programme of CEN / TC 250)

Editors: G. Sedlacek, Ch. Heinemeyer, Chr. Butz

EUR 24084 EN - 2009

The mission of the JRC-IPSC is to provide research results and to support EU policy-makers in their effort towards global security and towards protection of European citizens from accidents, deliberate attacks, fraud and illegal actions against EU policies.

European Commission  
Joint Research Centre  
Institute for the Protection and Security of the Citizen

The European Convention for Constructional Steelworks (ECCS) is the federation of the National Associations of Steelworks industries and covers a worldwide network of Industrial Companies, Universities and Research Institutes.  
<http://www.steelconstruct.com/>

### **Contact information**

Address: Mies-van-der-Rohe-Straße 1, D-52074 Aachen

E-mail: [sed@stb.rwth-aachen.de](mailto:sed@stb.rwth-aachen.de)

Tel.: +49 241 80 25177

Fax: +49 241 80 22140

<http://ipsc.jrc.ec.europa.eu/>  
<http://www.jrc.ec.europa.eu/>

### **Legal Notice**

Neither the European Commission nor any person acting on behalf of the Commission is responsible for the use which might be made of this publication.

***Europe Direct is a service to help you find answers  
to your questions about the European Union***

**Freephone number (\*):**

**00 800 6 7 8 9 10 11**

(\*) Certain mobile telephone operators do not allow access to 00 800 numbers or these calls may be billed.

A great deal of additional information on the European Union is available on the Internet.  
It can be accessed through the Europa server <http://europa.eu/>

JRC 55118

EUR 24084 EN

ISBN 978-92-79-14094-5

ISSN 1018-5593

DOI 10.2788/4640

Luxembourg: Office for Official Publications of the European Communities

© European Communities, 2009

Reproduction is authorised provided the source is acknowledged

*Printed in Italy*

## Acknowledgements

This report is based on the results of two European research projects funded by the Research Fund for Coal and Steel (RFCS), namely:

- Generalisation of criteria for floor vibrations for industrial, office and public buildings and gymnastic halls – **VOF** prepared by ArcelorMittal, TNO, SCI, RWTH Aachen University [1]
- Human induced vibrations of steel structures – **HIVOSS** prepared by ArcelorMittal, TNO, SCI, RWTH Aachen University, CTICM, FEUP and Schlaich Bergermann und Partner [2]

The project partners gratefully acknowledge the financial contributions of RFCS as well as their agreement to publish the results in a "JRC-Scientific and Technical Report" to support the maintenance, further harmonization, further development and promotion of the Eurocodes.

## Foreword

- (1) The EN Eurocodes are a series of European Standards which provide a common series of methods for calculating the mechanical strength of elements playing a structural role in construction works, i.e. the structural construction products.

They enable to design construction works, to check their stability and to give the necessary dimensions to the structural construction products.

- (2) They are the result of a long procedure of bringing together and harmonizing the different design traditions in the Member States. In the same time, the Member States keep exclusive competence and responsibility for the levels of safety of works.

- (3) Sustainability requirements for buildings often lead to structural concepts, for which the mechanical resistance and stability of construction works is not governing the design, but serviceability criteria can control the dimensions. A typical example are long span lightweight floor structures, for which the design for vibrations to avoid discomfort provides the main design parameters.

- (4) So far for floor structures the Eurocodes give only recommendations for estimated limits for eigenfrequencies, e.g. 3 Hz or 8 Hz depending on the construction material, or they give reference to ISO-standards as ISO/DIS 10137 and ISO 2631, which give general criteria for the perception of vibrations and could be the basis to develop more detailed design rules for vibrations specific to particular structures and types of excitation.

- (5) This report is intended to fill this gap and to provide an easy-to-use design guide with background information that shall help to specify comfort requirements for occupants and to perform a design that guarantees the specified comfort.

- (6) It applies to floors in office and/or residential buildings that might be excited by walking persons and which can affect the comfort of other building users.

- (7) This report may be considered as a supplement to EN 1990 and may also be used as a source of support to:
  - further harmonization of the design rules across different structural materials and construction procedures,
  - further development of the Eurocodes.

- (8) The rules for the "Design of floor structures for human induced vibrations" given in this report are the result of two international projects, the VOF-project and the HIVOSS-project, both funded by the Research Fund for Coal and Steel (RFCS), initiated and carried out by a group of experts from RWTH Aachen University, Germany, ArcelorMittal, Luxembourg, TNO, The Netherlands, SCI, United Kingdom, CTICM, France, FEUP Porto, Portugal and Schlaich, Bergermann und Partner, Germany [1], [2]
- (9) The agreement of RFCS and the project partners to publish this report in the series of the "JRC-Scientific and Technical Reports" in support of the further development of the Eurocodes is highly appreciated.
- (7) The examples given in this guideline mainly covers light-weight steel structures, where the consideration of human induced vibrations is part of the optimization strategy for sustainable constructions. Therefore, the publication has been carried out in the context of the JRC-ECCS-cooperation agreement in order to support the further harmonization of National procedures and the further evolution of the Eurocodes.

Aachen, Delft, Paris and Ispra, September 2009

Gerhard Sedlacek  
ECCS-Director of Research

Frans Bijlaard  
Chairman of CEN/TC 250/SC3

Jean-Armand Calgaro  
Chairman of CEN/TC 250

Michel Gérardin, Artur Pinto, Humberto Varum  
European Laboratory for Structural Assessment, IPSC, JRC

# **Design of floor structures for human induced vibrations**



## List of Contents

1	Objective .....	5
2	General procedure .....	6
3	Description of the loading.....	7
4	Dynamic floor response .....	13
5	Comfort assessment of the floor structures.....	17
6	Development of design charts.....	26
7	Guidance for the design of floors for human induced vibrations using design charts .....	29
7.1	Scope .....	29
7.2	Procedure.....	29
7.3	Determination of dynamic properties of floor structures .....	30
7.4	Values for eigenfrequency and modal mass .....	31
7.4.1	Simple calculation formulas for isotropic plates and beams.....	31
7.4.2	Simple calculation methods for eigenfrequencies of orthotropic floors.....	34
7.4.3	Natural frequencies from the self-weight approach.....	35
7.4.4	Natural frequency from the Dunkerley approach .....	36
7.4.5	Modal mass from mode shape.....	37
7.4.6	Eigenfrequencies and modal mass from FEM-analysis .....	39
7.5	Values for damping.....	39
7.6	Determination of the appropriate $OS-RM_{90}$ -value.....	40
7.7	Vibration performance assessment.....	51
8	Design examples.....	52
8.1	Filigree slab with ACB-composite beams (office building).....	52
8.1.1	Description of the floor .....	52
8.1.2	Determination of dynamic floor characteristics .....	56
8.1.3	Assessment.....	58
8.2	Three storey office building.....	58
8.2.1	Description of the floor .....	58
8.2.2	Determination of dynamic floor characteristics .....	60
8.2.3	Assessment.....	63
9	References.....	64

## Table of definitions and frequently used symbols

### Definitions

The definitions given here are oriented on the application of this guideline.

Damping $D$	Damping is the energy dissipation of a vibrating system. The total damping consists of <ul style="list-style-type: none"><li>• material and structural damping</li><li>• damping by furniture and finishing (e.g. false floor)</li><li>• geometrical radiation (propagation of energy through the structure)</li></ul>
Modal mass $M_{\text{mod}}$ generalised mass	In many cases, a system with $n$ degrees of freedom can be reduced to a $n$ SDOF systems with frequency: $f_i = \frac{1}{2\pi} \sqrt{\frac{K_{\text{mod},i}}{M_{\text{mod},i}}}$ where: $f_i$ is the natural frequency of the $i$ -th system $K_{\text{mod},i}$ is the modal stiffness of the $i$ -th system $M_{\text{mod},i}$ is the modal mass of the $i$ -th system Thus, the modal mass can be interpreted to be the mass activated in a specific mode. The determination of the modal mass is described in section 7.

<p>Natural frequency <math>f =</math> Eigenfrequency</p>	<p>Each mode of a structure has its specific dynamic behaviour with regard to vibration mode shape and period <math>T</math> [s] of a single oscillation. The frequency <math>f</math> is the reciprocal of the oscillation period <math>T</math> (<math>f = 1/T</math>).</p> <p>The natural frequency is the frequency of a free decaying oscillation without continuously being driven by an excitation source.</p> <p>Each structure has as many natural frequencies and associated mode shapes as degrees of freedom. They are commonly sorted by the amount of energy that is activated by the oscillation. Therefore, the first natural frequency is that on the lowest energy level and is thus the most likely to be activated.</p> <p>The equation for the natural frequency of a single degree of freedom system is</p> $f = \frac{1}{2\pi} \sqrt{\frac{K}{M}}$ <p>where:        <math>K</math>        is the stiffness                   <math>M</math>        is the mass</p>
<p><math>OS-RMS_{90}</math></p>	<p>One-Step-RMS-value of the acceleration resp. velocity for a significant single step, that is larger than the 90% fractile of peoples' walking steps.</p> <p><math>OS</math>:    One step</p> <p><math>RMS</math>:    Root mean square = effective value of the acceleration <math>a</math> resp. velocity <math>v</math>:</p> $a_{RMS} = \sqrt{\frac{1}{T} \int_0^T a(t)^2 dt} \approx \frac{a_{Peak}}{\sqrt{2}}$ <p>where:        <math>T</math>        is the period.</p>

## Variables, units and symbols

$a$	Acceleration	[m/s <sup>2</sup> ]
$B$	Width	[m]
$D$	Damping ratio (% of critical damping)	[-]
$D_1$	Structural damping ratio	[-]
$D_2$	Damping ratio from furniture	[-]
$D_3$	Damping ratio from finishings	[-]
$\delta(x,y)$	Deflection at location $x,y$	[m]
$\delta$	Deflection	[m]
$E$	Young's modulus	[kN/cm <sup>2</sup> ]
$f, f_i$	Natural frequency	[Hz]
$f_s$	Walking frequency	[Hz]
$G$	Body weight	[kg]
$K, k$	Stiffness	[N/m]
$l$	Length	[m]
$M_{\text{mod}}$	Modal mass	[kg]
$M_{\text{total}}$	Total mass	[kg]
$\mu$	Mass distribution per unit of length or per unit of area	[kg/m] or [kg/m <sup>2</sup> ]
OS-RMS	One step root mean square value of the effective velocity resp. acceleration	[-]
OS-RMS <sub>90</sub>	90 % fractile of OS-RMS values	[-]
$p$	Distributed load (per unit of length or per unit of area)	[kN/m] or [kN/m <sup>2</sup> ]
$T$	Period (of oscillation)	[s]
$t$	Time	[s]
$t$	Thickness	[m]
$v$	Velocity	[mm/s]

# 1 Objective

Sustainability requires multi-storey buildings built for flexible use concerning space arrangement and usage. In consequence large span floor structures with a minimum number of intermediate columns or walls are of interest.

Modern materials and construction processes, e.g. composite floor systems or prestressed flat concrete floors with high strengths, are getting more and more suitable to fulfil these requirements.

These slender floor structures have in common, that their design is usually not controlled by ultimate limit states but by serviceability criteria, i.e. deflections or vibrations.

Whereas for ultimate limit state verifications and for the determination of deflections design codes provide sufficient rules, the calculation and assessment of floor vibrations in the design stage has still a number of uncertainties.

These uncertainties are related to:

- a suitable design model including the effects of frequencies, damping, displacement amplitudes, velocity and acceleration to predict the dynamic response of the floor structure with sufficient reliability in the design stage,
- the characterisation of boundary conditions for the model,
- the shape and magnitude of the excitation,
- the judgement of the floor response in light of the type of use of the floor and acceptance of the user.

This report gives a procedure for the determination and assessment of floor responses to walking of pedestrians which on one side takes account of the complexity of the mechanical vibrations problem, but on the other side leads – by appropriate working up-to easy-to-use design charts.

## 2 General procedure

The procedure for the determination of an acceptable floor response to excitation induced by walking persons is based on the following:

1. the characteristics of the **loading** by identifying the appropriate features of the walking process by describing the load-time-history as a function of body weight, step frequency and their statistical demographic distribution,
2. the identification of the **dynamic floor response** from representative "Single degree of freedom"-models for different typologies of floors, to which actions in the form of parameterized time-histories of step forces are applied; these responses are given as time-histories or frequency distributions for further evaluations,
3. the **comfort assessment** of the floor responses taking into account human perception and condensation of data to a single representative response parameter (OS-RMS-value<sub>90</sub>) which defines a certain fractile of the distribution of responses to actions and is suitable for being compared with response requirements depending on the type of building and its use.

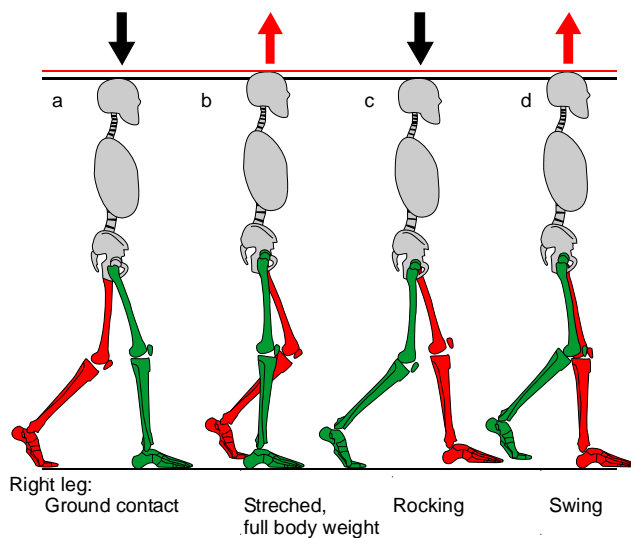
The procedure has been used to develop design diagrams, the use of which is demonstrated by worked examples.

### 3 Description of the loading

Walking of a person differs from running, because one foot keeps continuously contact to the ground while the other foot moves. It can be described by the time history of walking induced contact forces.

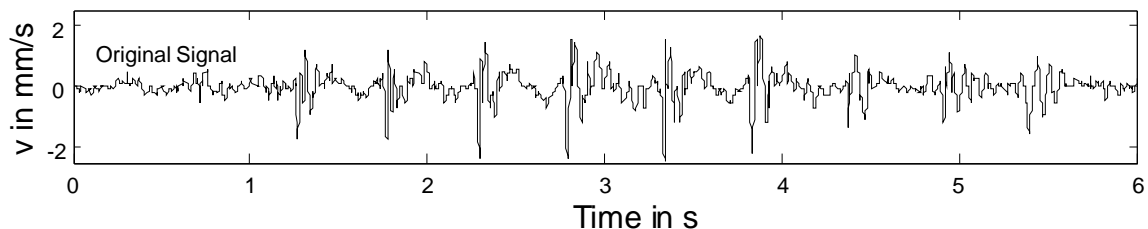
The movement phases of a single leg, as illustrated in **Figure 3-1**, are the following:

- a) The right foot touches the ground with the heel. This is the starting point of the contact forces.
- b) The right leg is stretched; it transmits the full body weight.
- c) Rocking: the right foot rocks while the left leg swings forward.
- d) The left foot touches the ground while the right leg swings forward.



**Figure 3-1: Movement phases of legs and feet during walking**

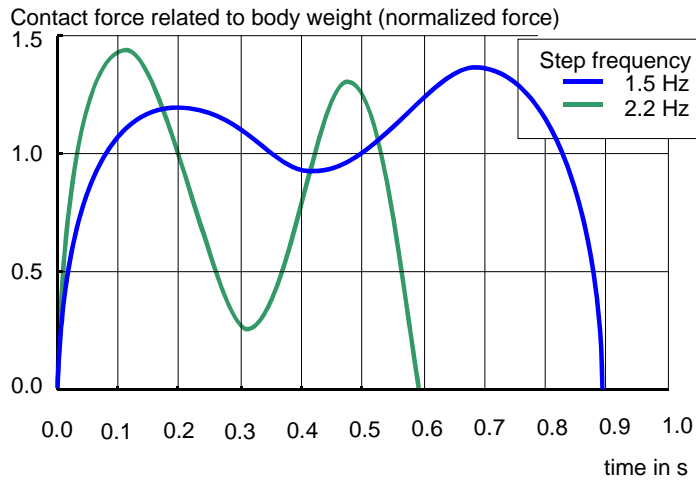
A typical velocity time history measured at a representative point of a floor structure excited by a walking person is given in **Figure 3-2**.



**Figure 3-2: Typical velocity response time history of a floor to walking loads**

Due to the periodicity of the contact forces it is possible to consider the time history of the contact force of a single step according to **Figure 3-1** only and to describe this force-time history in a normalised way.

**Figure 3-3** gives an example for the time history of the contact forces for two different step frequencies, where the amplitudes are normalized by relating them to the body weight  $G$  of the person.



**Figure 3-3: Example for the time history of the normalised contact forces for two different step frequencies**

The standard walking load of a person can then be described as a series of consecutive steps, where each step is given by a polynomial function, as given in **Table 3-1**.



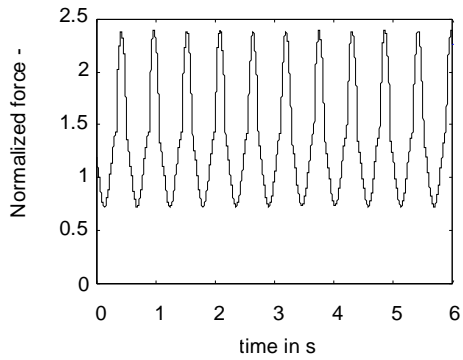
Polynomial function for the contact force due to a single step:			
$\frac{F(t)}{G} = K_1t + K_2t^2 + K_3t^3 + K_4t^4 + K_5t^5 + K_6t^6 + K_7t^7 + K_8t^8$			
Coefficient	step frequency ranges		
	$f_s \leq 1.75$ Hz	$1.75 < f_s < 2$ Hz	$f_s \geq 2$ Hz
$K_1$	$-8 \times f_s + 38$	$24 \times f_s - 18$	$75 \times f_s - 120$
$K_2$	$376 \times f_s - 844$	$-404 \times f_s + 521$	$-1720 \times f_s + 3153$
$K_3$	$-2804 \times f_s + 6025$	$4224 \times f_s - 6274$	$17055 \times f_s - 31936$
$K_4$	$6308 \times f_s - 16573$	$-29144 \times f_s + 45468$	$-94265 \times f_s + 175710$
$K_5$	$1732 \times f_s + 13619$	$109976 \times f_s - 175808$	$298940 \times f_s - 553736$
$K_6$	$-24648 \times f_s + 16045$	$-217424 \times f_s + 353403$	$-529390 \times f_s + 977335$
$K_7$	$31836 \times f_s - 33614$	$212776 \times f_s - 350259$	$481665 \times f_s - 888037$
$K_8$	$-12948 \times f_s + 15532$	$-81572 \times f_s + 135624$	$-174265 \times f_s + 321008$

**Table 3-1: Determination of the normalized contact forces**

The load duration  $t_s$  of a single footfall is given by

$$T_s = 2.6606 - 1.757 f_s + 0.3844 f_s^2.$$

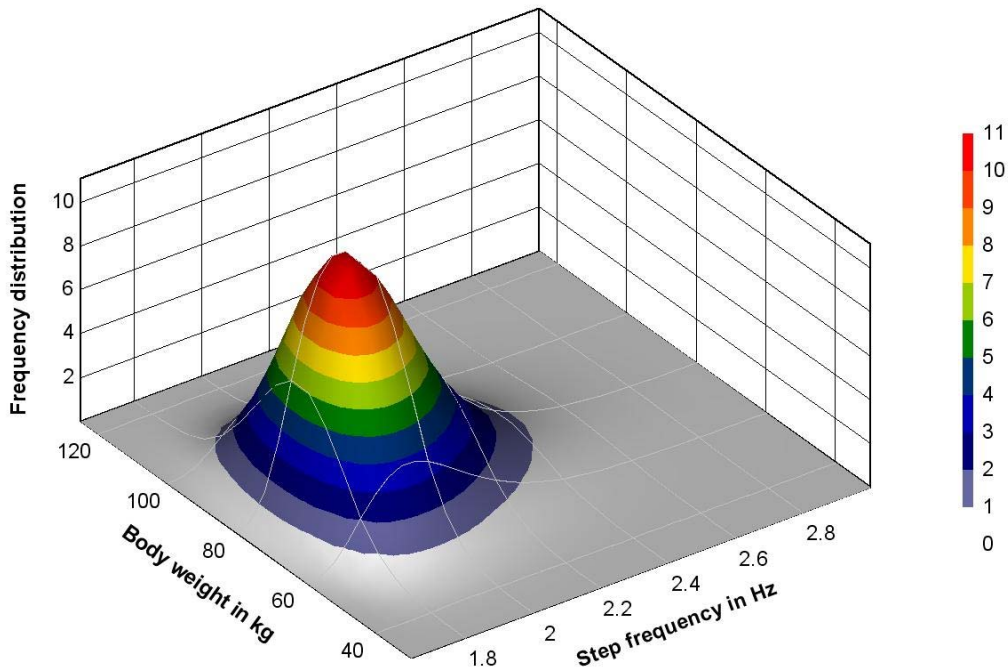
**Figure 3-4** gives an example of a standard walking load history which is composed by a repetition of normalized contact forces at intervals of  $\frac{1}{f_s}$ .



**Figure 3-4: Example of a walking load function composed of normalized contact forces**

In order to obtain information on the statistical distributions of walking frequencies  $f_s$  and body weights  $G$  of persons, measurements of step frequencies were carried out in the entrance area of the TNO building in Delft (in total 700 persons) and the distribution of step frequencies were correlated with the distribution of body mass, as published for Europe, assuming that step frequencies and body masses would be statistically independent.

**Figure 3-5** gives the distribution of step frequencies and body mass and **Table 3-2** gives the associated cumulative distributions.



**Figure 3-5: Frequency distribution of body mass and step frequency for a population of data of 700**

Classes of step frequency $f_{sm}$ $m = 1 + 35$		Classes of masses $M_n$ $n = 1 + 20$	
Cumulative probability	Step frequency $f_s$ (Hz)	Cumulative probability	Step frequency $f_s$ (Hz)
0,0003	1,64	0,0000	30
0,0035	1,68	0,0002	35
0,0164	1,72	0,0011	40
0,0474	1,76	0,0043	45
0,1016	1,80	0,0146	50
0,1776	1,84	0,0407	55
0,2691	1,88	0,0950	60
0,3679	1,92	0,1882	65
0,4663	1,96	0,3210	70
0,5585	2,00	0,4797	75
0,6410	2,04	0,6402	80
0,7122	2,08	0,7786	85
0,7719	2,12	0,8804	90
0,8209	2,16	0,9440	95
0,8604	2,20	0,9776	100
0,8919	2,24	0,9924	105
0,9167	2,28	0,9978	110
0,9360	2,32	0,9995	115
0,9510	2,36	0,9999	120
0,9625	2,40	1,0000	125
0,9714	2,44		
0,9782	2,48		
0,9834	2,52		
0,9873	2,56		
0,9903	2,60		
0,9926	2,64		
0,9944	2,68		
0,9957	2,72		
0,9967	2,76		
0,9975	2,80		
0,9981	2,84		
0,9985	2,88		
0,9988	2,92		
0,9991	2,96		
0,9993	3,00		

**Table 3-2: Cumulative probability distribution functions for step frequency  $f_{s,m}$  and body mass  $M_n$**

The functions for contact forces in **Figure 3-3** and the distributions of step frequency and body mass are the input data for calculating the dynamic responses of floor structures. The 20 classes of body mass and the 35 classes of step frequency as given in **Table 3-2** were used (in total 700 combinations) to develop design charts.

## 4 Dynamic floor response

The dynamic response of a floor structure to persons walking is controlled by the loading characteristics, as described in Section 3, and by the structural dynamic properties of the floor.

The dynamic properties of the floor structure relevant to the floor response are, for each vibration mode  $i$ :

- the eigenfrequency  $f_i$ ,
- the modal mass  $M_{\text{mod},i}$ ,
- the damping value  $D_i$ .

The various modes  $i$  are normally arrayed according to their energy contents. The first mode ( $i = 1$ ) needs the smallest energy content to be excited.

When the eigenfrequency of a mode and the frequency of steps are identical, resonance can lead to very large response amplitudes. Resonance can also occur for higher modes, i.e. where the multiple of the step frequency coincides with a floor frequency.

The response amplitudes of floor structures due to walking of persons are in general limited by the following effects:

- the mass of the floor structure. As the number of step impulses is limited by the dimensions of the floor (walking distances), the ratio of the body mass to the excited floor mass influences the vibration,
- the damping  $D$  that dissipates excitation energy. The damping  $D_i$  consists of the structural damping  $D_1$ , e.g. due to inner friction within the floor structure or in connections of the floor to other structural components such as supports, of the damping  $D_2$  from furniture and equipment and of the damping  $D_3$  from further permanent installations and finishings.

**Table 4-1** gives an overview on typical damping values as collected from various sources of literature [6].

Type	Damping (% of critical damping)
Structural Damping $D_1$	
Wood	6%
Concrete	2%
Steel	1%
Composite	1%
Damping due to furniture $D_2$	
Traditional office for 1 to 3 persons with separation walls	2%
Paperless office	0%
Open plan office.	1%
Library	1%
Houses	1%
Schools	0%
Gymnasium	0%
Damping due to finishings $D_3$	
Ceiling under the floor	1%
Free floating floor	0%
Swimming screed	1%
<b>Total Damping <math>D = D_1 + D_2 + D_3</math></b>	

**Table 4-1: Components of damping**

**Figure 4-1** demonstrates by means of a flow chart how floor responses in terms of time histories or frequency spectra of velocity have been calculated for various floor systems  $k$ , which were used for further evaluation.

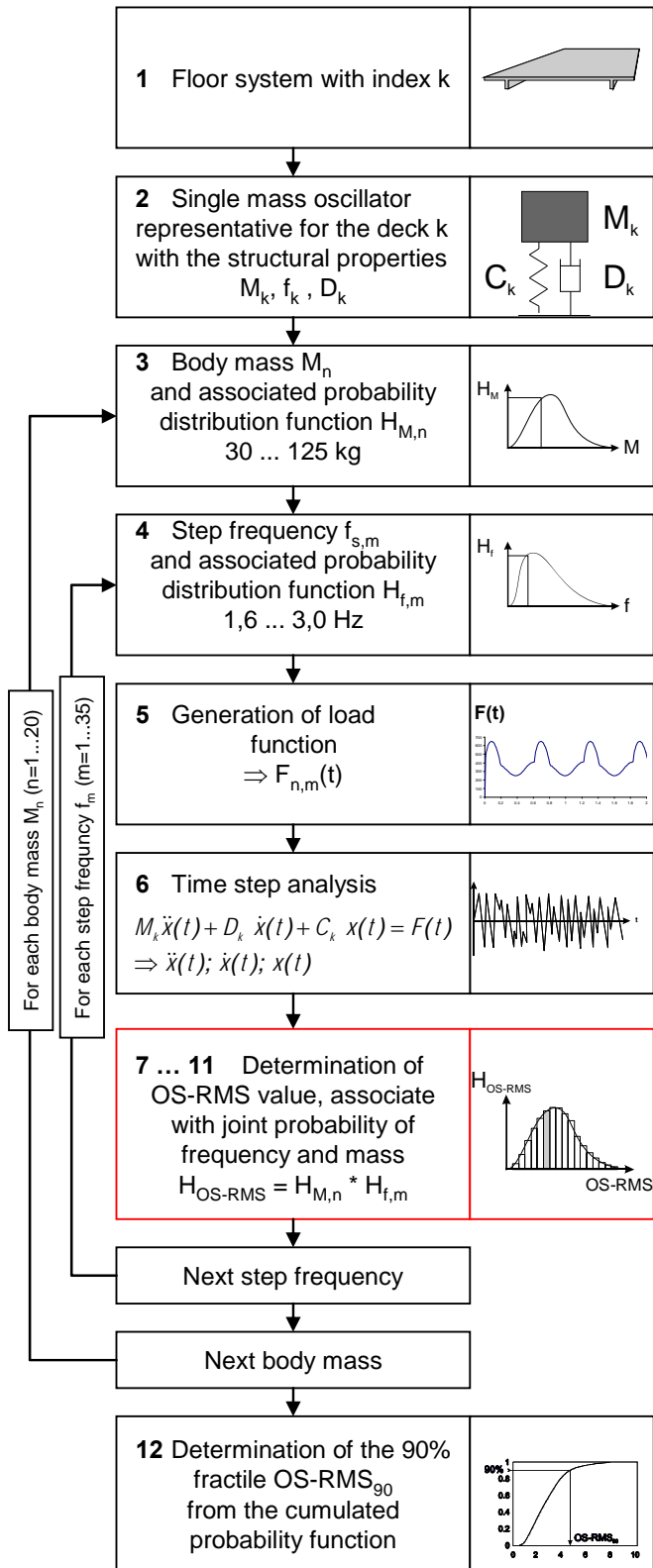
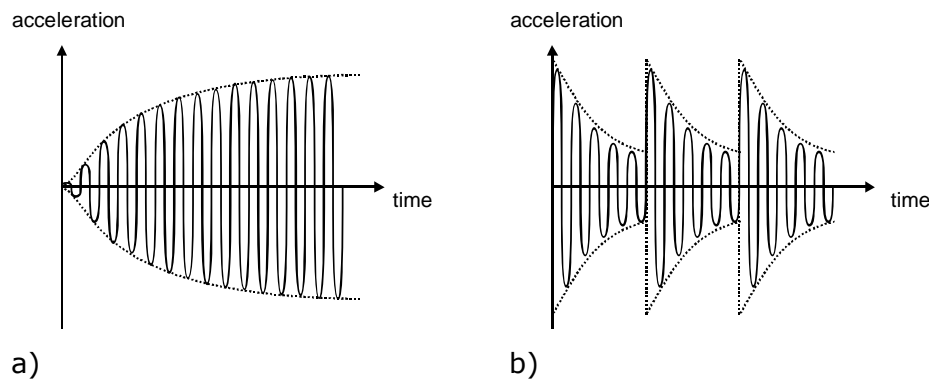


Figure 4-1: Flow chart for calculation of dynamic floor responses to walking excitations by a person with the mass  $M_n$  and the frequency  $f_m$ , see also Figure 5-5

In these calculations the excitation point is assumed to be stationary , i.e. the walking path is not taken into consideration. In general, the location of the stationary excitation and hence the location of the response are selected where the largest vibration amplitudes are expected (for regular floors it is usually the middle of the floor span).

Apart from excitation by the regular walking also the excitation from single impacts, e.g. from heel drop may occur that leads to transient vibrations. This report only refers to excitation from regular walking because experience shows that for floor structures with lowest eigenfrequency  $f_s \leq 7$  Hz walking is the relevant excitation type, whereas heel drop is only relevant for fundamental eigenfrequencies  $f_s > 7$  Hz.

In general, the time response of a floor system to regular excitation by walking take the form of one of the plots given in **Figure 4-2**.



**Figure 4-2: Possible envelopes of dynamic responses of a floor to regular excitation a) resonant response, b) transient response**

If the excitation frequency (or higher harmonics of the excitation) is similar to an eigenfrequency of the floor, the response takes the form as shown in **Figure 4-2 a)**: a gradually increasing of the response envelope until a steady-state level. This response is known as either resonant response or steady state response. This kind of response can occur for floors with a fundamental natural frequency inferior to 9-10 Hz.

If the excitation frequency is significantly lower than the natural frequency of the floor, the response envelope shown in **Figure 4-2 b)** is typical, known as transient response. In this case, the floor structure responds to the excitation as if it is a series of impulses with the vibration due to one foot step dying away before the next step impulse.



## 5 Comfort assessment of the floor structures

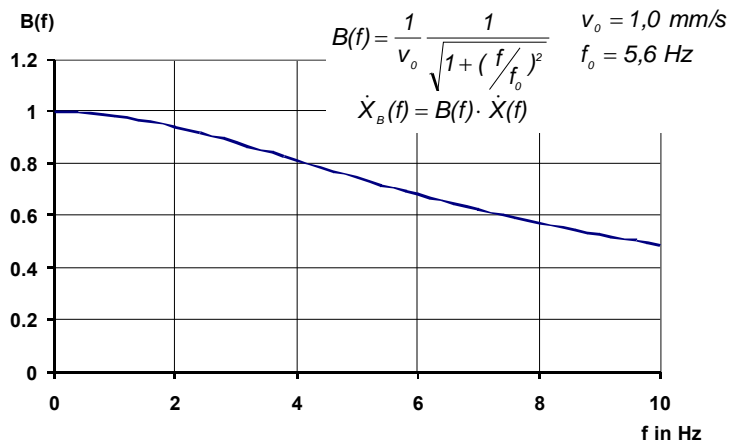
The purpose of the comfort assessment of the floor structures is a design, by that vibrations are so small, that adequate comfort of the users is obtained.

This comfort assessment implies the use of a single response parameter that reflects both, the comfort perception of users and the dynamic response of the floor structure.

The definition of such a parameter requires various assumptions:

1. a weighting of the frequencies obtained from the response of the floor structure to take the frequency dependence of human perception into account. In a similar way to human hearing, the human perception of vibration varies with the frequency.

The weighting function used applies to the response in terms of velocity, see **Figure 5-1**:



**Figure 5-1: Weighting function for the spectrum of vibration velocities**

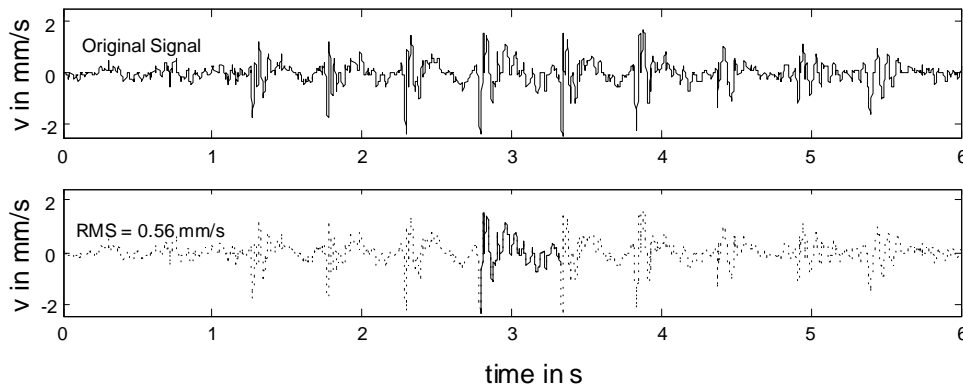
The weighting function achieves that the weighted response is dimensionless.

2. Use of RMS-values (Root mean square values) as effective response values by evaluation of a time window  $T_s$ :

$$RMS_{n,m} = \sqrt{\frac{1}{T_s} \int_t^{t+T_s} \dot{x}_B^2(t) dt}$$

3. Definition of the time window  $T = T_s$ . If  $T_s$  is too long, the results are smeared, if  $T_s$  is too short, the results are arbitrarily.

The well-proven definition of the time window  $T_s$  is the time interval of standard contact force for a single step according to **Figure 3-3**, see **Figure 5-2**.

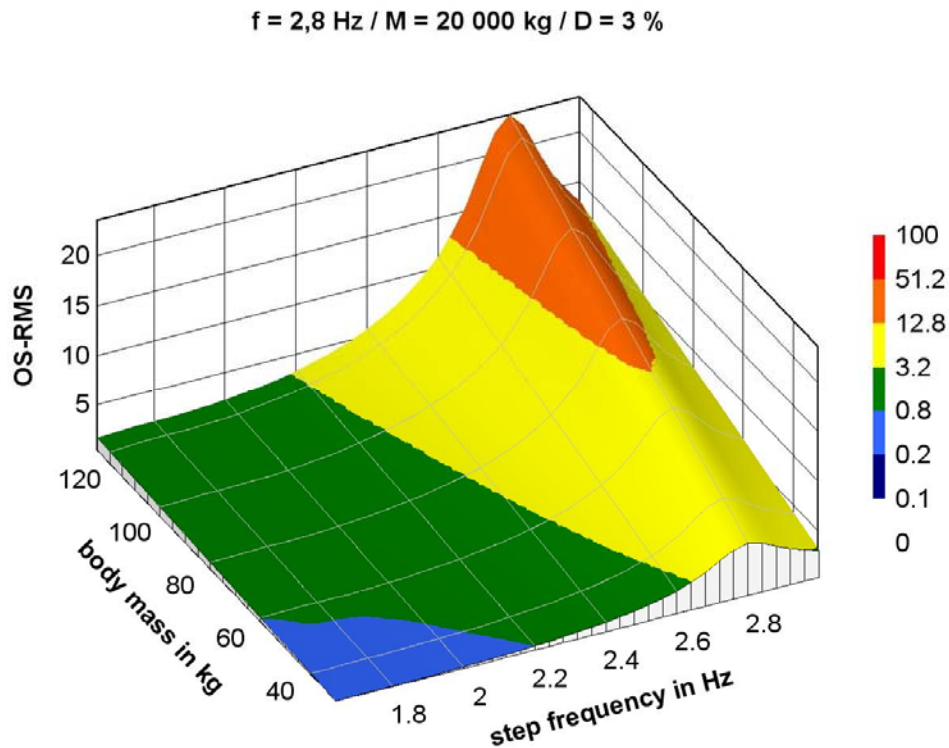


**Figure 5-2: Selection of the time window  $T_s$  for the RMS-value of the weighted velocity response**

This definition leads to the “one step-root mean square value”, so called OS-RMS-value, which is independent on the step frequency and duration of time interval:

$$OS - RMS_{n,m} = \sqrt{\frac{1}{T_s} \int_t^{t+T_s} \dot{x}_B^2(t) dt}$$

**Figure 5-3** gives as an example for a floor structure with the dynamic properties  $f = 2.8$  Hz,  $M_{\text{mod}} = 20000$  kg,  $D = 3\%$  the OS-RMS-value as a function of the step frequency and of the body mass.



**Figure 5-3:** Example for OS-RMS-values as a function of step frequency and body mass

The results in **Figure 5-3** do however not yet consider effects of the frequency distributions of the step frequency  $f_s$  and of the body mass  $G$ .

They may be agglomerated to a cumulative frequency distribution, see **Figure 5-4**.

4. Accounting for the frequency distribution  $H_{f_m}$  of the step frequency  $f_s$  and the body mass  $G$ .

The classes of OS-RMS-values  $H_{OS-RMS}$  in **Figure 5-3**, are multiplied with the cumulative probability distributions  $H_{f_m}$ . In conclusion a cumulative distribution of OS-RMS-values is obtained according to **Figure 5-4**, that also contains the results.

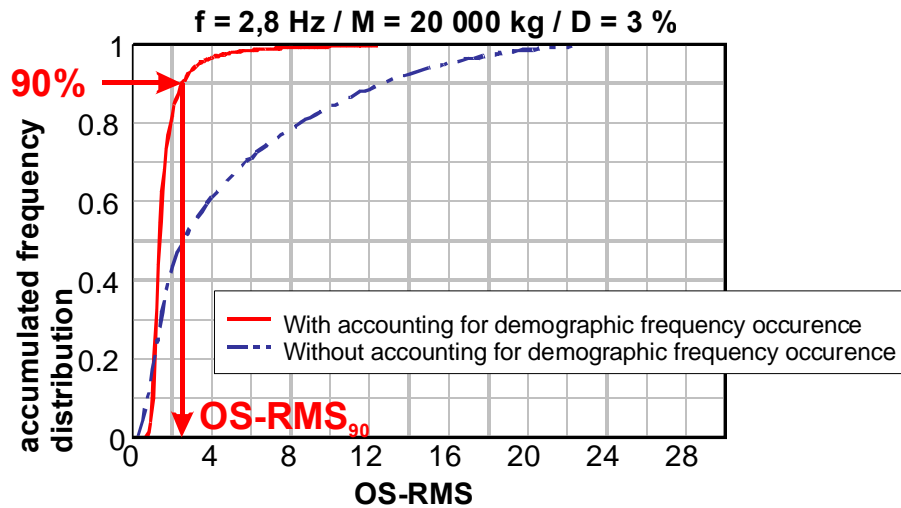
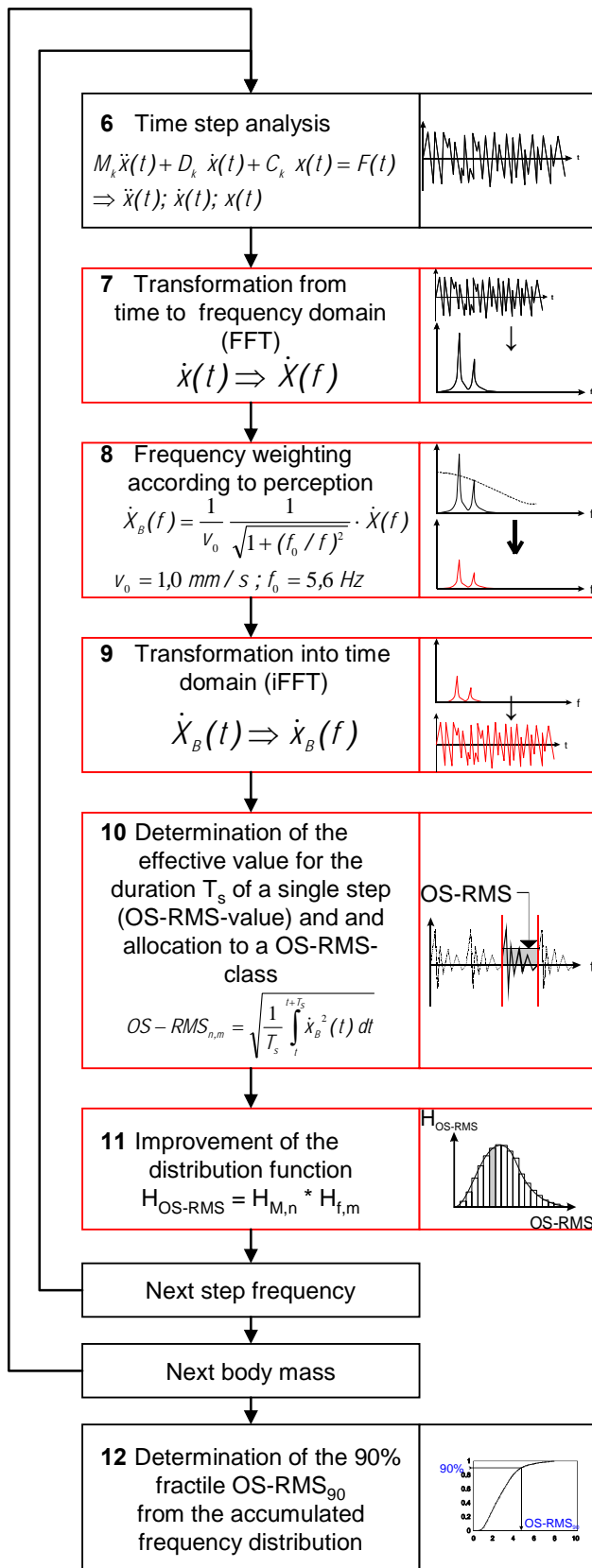


Figure 5-4: Cumulative frequency distribution of OS-RMS-values with and without taking the frequency distribution  $H_{fm}$  into account

5. Definition of a representative OS-RMS-value to obtain the desired reliability. This representative value is defined as the 90 %-fractile of OS-RMS-values from the cumulative frequency distribution, as indicated in **Figure 5-4**, which is denoted as  $OS-RMS_{90}$ .

**Figure 5-5** gives an overview of the various steps to obtain the  $OS-RMS_{90}$  values by means of a flow chart.



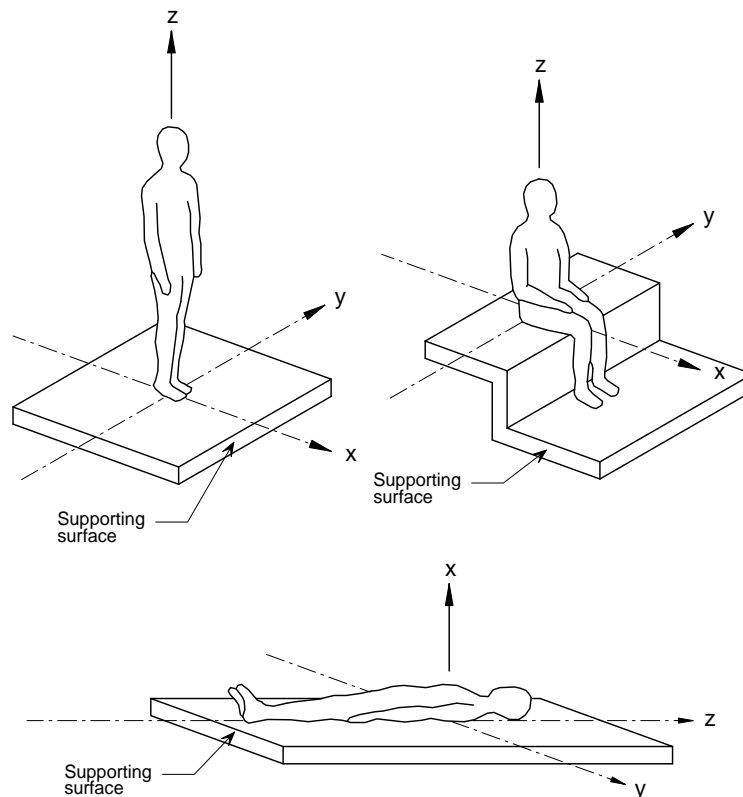
**Figure 5-5:** Flow chart for the evaluation of dynamic floor-response to walking excitations by a person with the mass  $M_n$  and the frequency  $f_m$  to obtain the  $OS-RMS_{n,m}$  values and their distribution

The limits for the  $OS-RMS_{90}$ -values for comfort are based on various standards for standardizing human perception [6], [7], [8], [9], [10], [11].

In general, the perception and the individual judgement, whether vibrations are disturbing or not (discomfort), are based on the same criteria but can lead to different limits, as certain persons can detect vibrations without being discomforted by them.

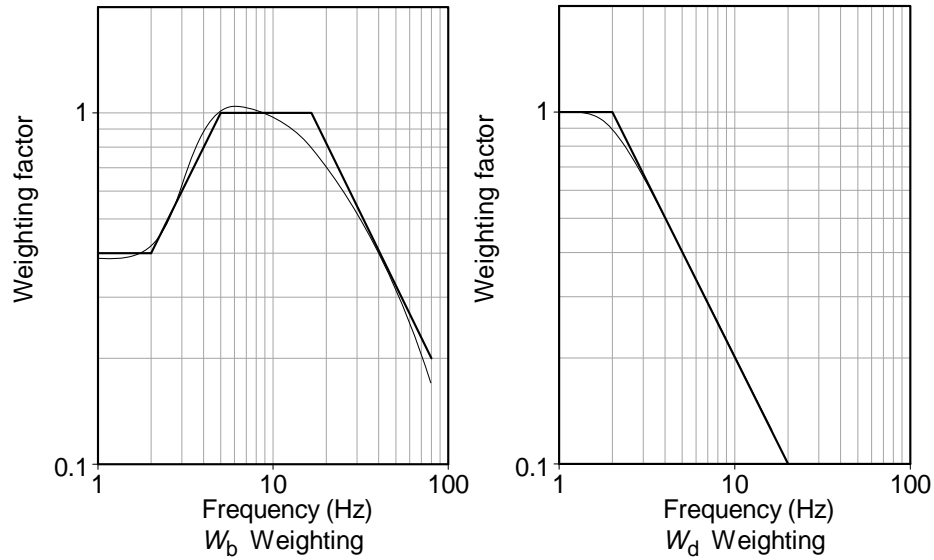
The governing parameters are e.g.:

- momentary activity of the user (manual work or sleeping),
- age and state of health of the user,
- posture of the user (sitting, standing, laying down), see **Figure 5-6**
- Relation between the user and the source of excitation (are vibrations expected or not),
- Frequency and amplitude of vibration (as taken into account by the weighting function).



**Figure 5-6: Directions for vibrations defined in ISO 10137 [6]**

**Figure 5-7** gives examples for curves of same perception for z-axis vibration ( $W_b$  curve) and x-and y-axis vibrations ( $W_d$  curve); e.g. according to the  $W_b$  curve a sine wave of 8 Hz is equivalent to a sine wave with 2.5 Hz or 32 Hz with double amplitude.




**Figure 5-7:  $W_b$  and  $W_d$  -weighting curves**

These parameters can be allocated to various classes of perception defined by lower and upper threshold values for the  $OS-RMS_{90}$ -values, that are suitable for being associated to certain typical usages of floors, see

**Table 5-1.**

Class	$OS-RMS_{90}$		Usage of the floor structure									
	Lower limit	Upper limit	Critical areas	Hospitals, surgeries	Schools, training centers	Residential buildings	Office buildings	Meeting rooms	Senior citizens' Residential building	Hotels	Industrial Workshops	Sports facilities
A	0.0	0.1	Recommended	Recommended	Recommended	Recommended	Recommended	Recommended	Recommended	Recommended	Recommended	Recommended
B	0.1	0.2	Critical	Recommended	Recommended	Recommended	Recommended	Recommended	Recommended	Recommended	Recommended	Recommended
C	0.2	0.8	Not recommended	Recommended	Recommended	Recommended	Recommended	Recommended	Recommended	Recommended	Recommended	Recommended
D	0.8	3.2	Not recommended	Critical	Critical	Recommended	Recommended	Recommended	Recommended	Recommended	Recommended	Recommended
E	3.2	12.8	Not recommended	Not recommended	Not recommended	Critical	Critical	Critical	Critical	Critical	Recommended	Recommended
F	12.8	51.2	Not recommended	Not recommended	Not recommended	Not recommended	Not recommended	Not recommended	Not recommended	Not recommended	Critical	Critical



Recommended

Critical

Not recommended

**Table 5-1: Allocation of classes of perception A to F to threshold values of  $OS-RMS_{90}$ -values and relation of occupancies of floors to comfort limits**

**Table 5-2** gives the background to **Table 5-2** from limits specified in ISO 10137 [6].



Usage	Time	Multiplying Factor	$OS-RMS_{90}$ equivalent
Critical working areas (e.g. hospitals operating-theatres, precision laboratories, etc.)	Day	1	0.1
	Night	1	0.1
Residential (e.g. flats, homes, hospitals)	Day	2 to 4	0.2 to 0.4
	Night	1.4	0.14
Quiet office, open plan	Day	2	0.2
	Night	2	0.2
General office (e.g. schools, offices)	Day	4	0.4
	Night	4	0.4
Workshops	Day	8	0.8
	Night	8	0.8

**Table 5-2: Vibration limits specified in ISO 10137 [6] for continuous vibration**

As it depends on the agreement between designer and client to define the serviceability limits of comfort for floor structures, the allocation of perception classes to comfort classes for various occupancies (**Table 5-1**) has the character of recommendations.

## 6 Development of design charts

The procedure described in sections 2 to 5 may be used as assumed in this report to calculate for other excitation mechanisms, e.g. for heel drop, the structural response and the associated  $OS-RMS_{g0}$ -values. But it has been used for the particular excitation by walking persons to develop design charts, which give a relationship between

- the modal mass  $M_{mod}$  of the floor structure [kg],
- the eigenfrequency  $f_i$  of the floor structure [Hz],
- the  $OS-RMS_{g0}$ -values and their association to perception classes A to F

all for a given damping ratio  $D$ .

**Figure 6-1** gives an example for such a design diagram for a damping ratio of 3 %.

Each point in this design chart is based on the statistical evaluation of 700 combination functions of step frequency and body mass.

Classification based on a damping ratio of 3%

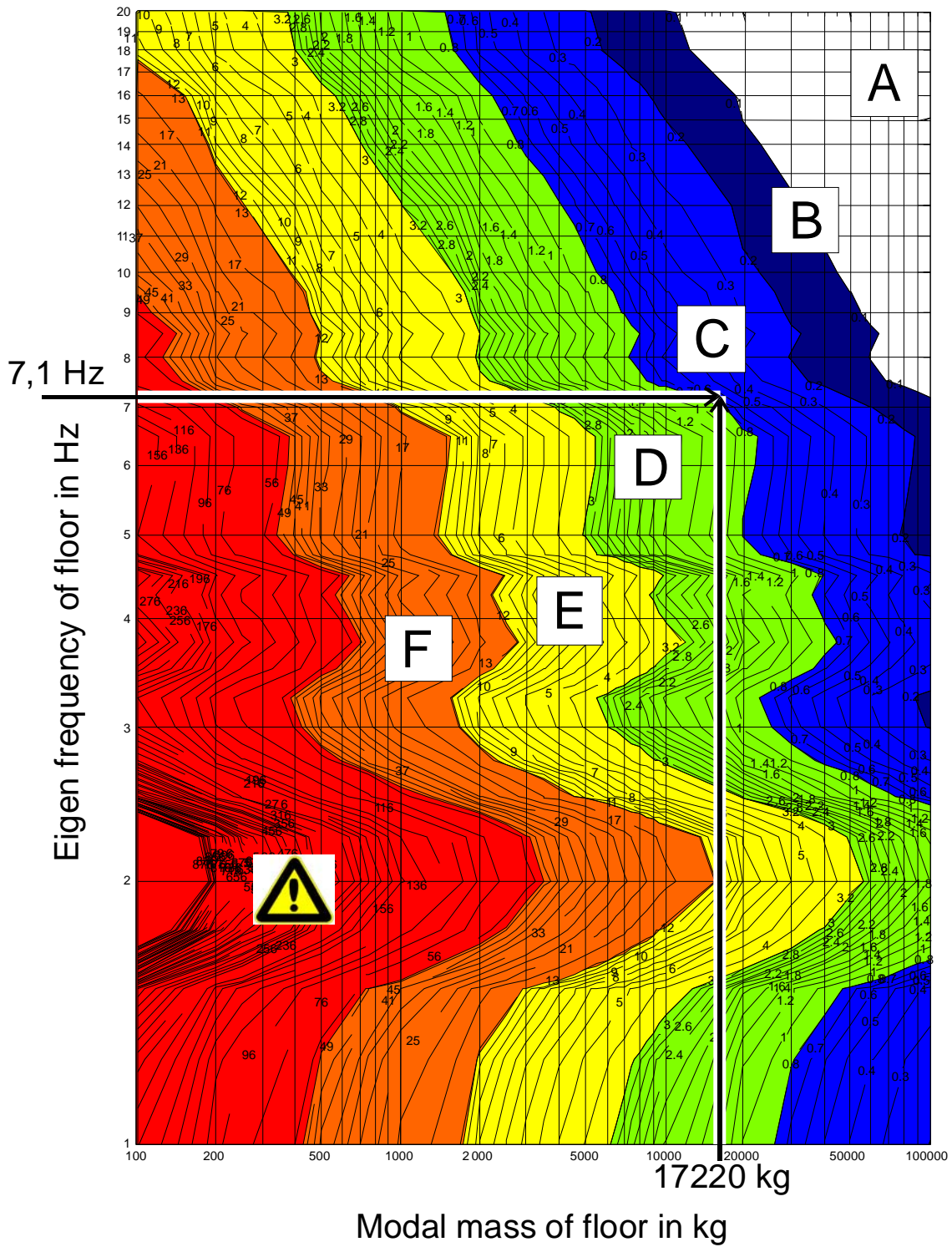
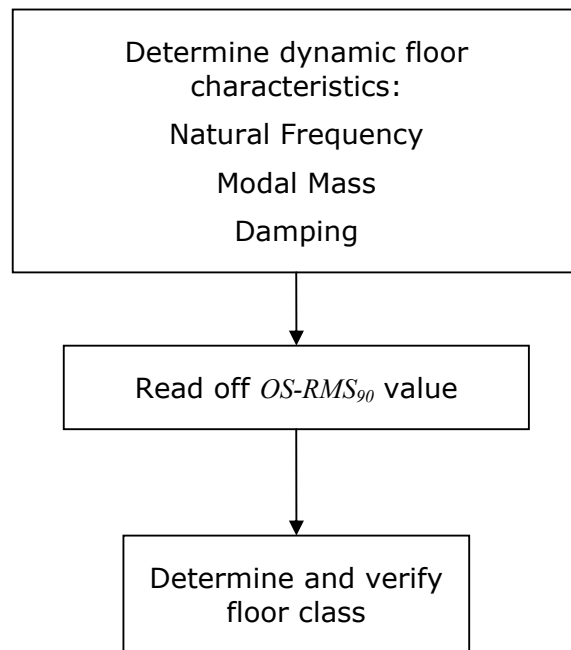


Figure 6-1: Example of a design chart for the vibration assessment of floor structures for a damping ratio  $D = 3\%$

The design procedure based on these design charts provides the following steps, see **Figure 6-2**:

1. Determination of the basic floor characteristics (natural frequency, modal mass, damping) for input,
2. Determination of the  $OS-RMS_{90}$ -value (90 % one-step RMS-value) from the design chart, which characterizes the floor response to walking,
3. Compare the  $OS-RMS_{90}$ -value with the recommended or required limits for the floor occupancy.



**Figure 6-2: Design procedure using the proposed design charts**

If the floor response is characterized by more than one natural frequency, the  $OS-RMS_{90}$ -value should be determined as a combination of  $OS-RMS_{90}$ -values obtained for each mode of vibration  $i$ :

$$OS - RMS_{90} = \sqrt{\sum_i (OS - RMS_{90})_i^2}$$

## 7 Guidance for the design of floors for human induced vibrations using design charts

### 7.1 Scope

This guidance provides a simplified method for determining and verifying floor design for vibrations due to walking developed with the procedure given in Section 2 to 6.

The guidance focuses on recommendations for the acceptance of vibration of floors which are caused by people during normal use. Human induced vibrations from rhythmic movements as dancing, gymnastic activities, jumping, machine induced vibrations or vibrations due to traffic etc. are not covered by this guidance.

The use of the guidance should be restricted to floors in buildings; it is not applicable to pedestrian bridges or other structures not comparable with floors.

The guidance focuses on the prediction and evaluation of vibration at the design level.

### 7.2 Procedure

The procedure used in this guidance needs the determination of the following values:

1. Dynamic properties of the floor structure:
  - eigenfrequency,
  - modal mass,
  - damping.

The dynamic properties should include a realistic assumption of the mechanical behaviour at the level of the vibration amplitudes expected (elastic behaviour), of the permanent mass and of the quasi permanent part of the mass of variable loads.

In case of very light floor structures also the mass from persons should be included in the floor mass.

2. The appropriate  $OS-RMS_{90}$ -value.

3. The relevant occupancy class or classes of the floor.
4. The requirement for comfort assessment.

### **7.3 Determination of dynamic properties of floor structures**

In general, the method for the determination of dynamic properties of floor structures should not be disproportionately more refined than the method for the vibration limit state assessment, which is basically a hand calculation method.

Hence, this method is part of the package agreed between the designer and the client in the design stage.

The hand calculation method for the determination of dynamic properties of floor-structures assumes that the dynamic response of the floor can be represented by a single degree of freedom system based on the fundamental eigenfrequency.

The eigenfrequency, modal mass and damping of this system can be obtained by

- calculation on the basis of the project documents or by
- measurements carried out at floor-structures which have been built and are used in a similar way as those projected and are suitable to be used as prototypes.

For the calculation of the stiffness of the structure and of the connections the initial elastic stiffness should be used, e.g. for concrete the dynamic modulus of elasticity should be considered to be 10 % larger than the static tangent modulus  $E_{cm}$ .

For calculation of the masses on the basis of project documents experienced values for the quasi permanent part of imposed loads for residential and office buildings are 10 % to 20 % of the mass of the characteristic values. For light-weight floors the mass of one person with a minimum mass of 30 kg is recommended to be added to the mass of the structure.

## 7.4 Values for eigenfrequency and modal mass

### 7.4.1 Simple calculation formulas for isotropic plates and beams

Table 7-1 gives hand formulas for the determination of the first natural frequency and the modal mass of isotropic plates for different supporting conditions. For the application of this table it is assumed that all four edges of the plate are linearly supported (no deflection of edges).

Table 7-2 gives hand formulas for beams for various support conditions.



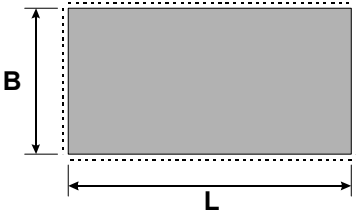
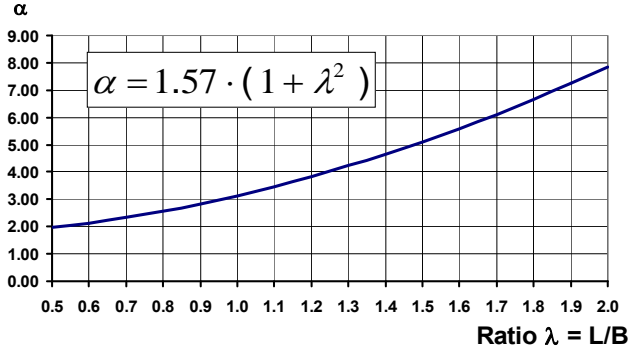
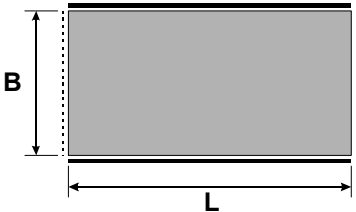
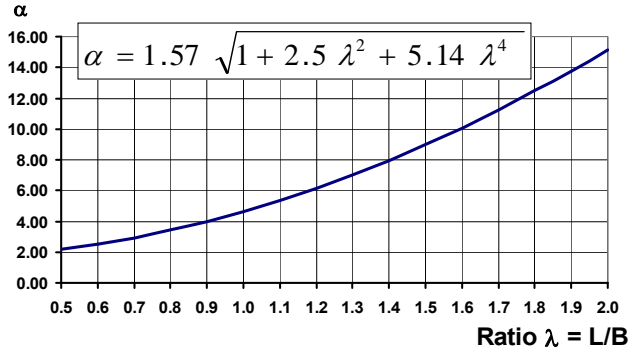



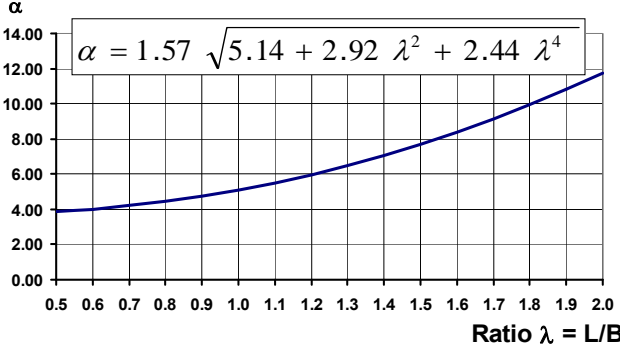

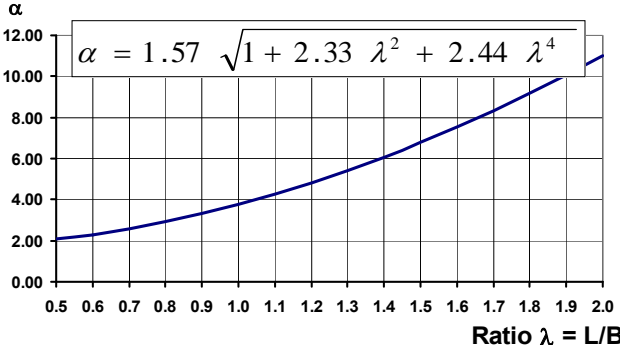
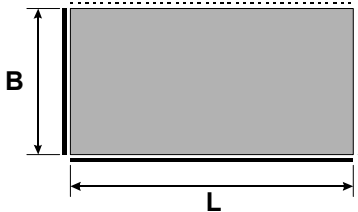
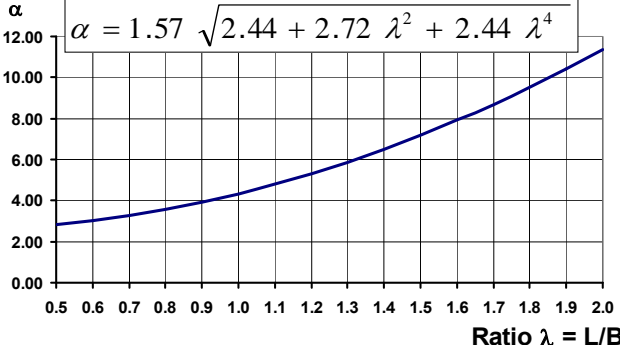


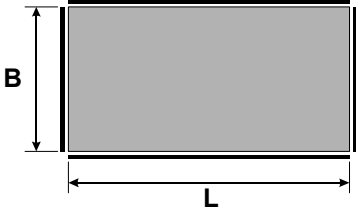
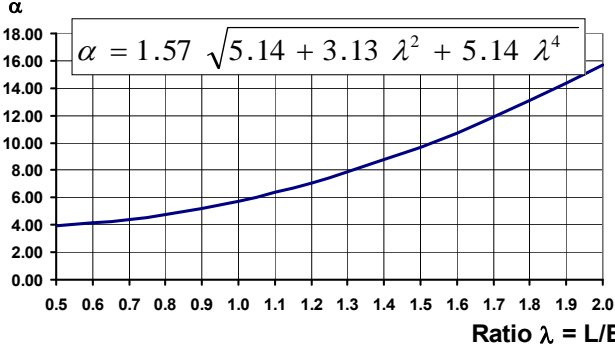
<p><b>Supporting Conditions:</b></p> <p>  <b>clamped</b>               <b>hinged</b> </p>	<p><b>Frequency ; Modal Mass</b></p> $f = \frac{\alpha}{L^2} \sqrt{\frac{E t^3}{12 \cdot \mu (1 - \nu^2)}} ; M_{\text{mod}} = \beta \cdot M_{\text{tot}}$
	 <p><math>\alpha = 1.57 \cdot (1 + \lambda^2)</math></p> <p><math>\beta \approx 0,25</math> for all <math>\lambda</math></p>
	 <p><math>\alpha = 1.57 \sqrt{1 + 2.5 \lambda^2 + 5.14 \lambda^4}</math></p> <p><math>\beta \approx 0.20</math> for all <math>\lambda</math></p>

Table 7-1: Natural frequencies and modal mass for isotropic plates

<p><b>Supporting Conditions:</b></p> <p> clamped     hinged</p>	<p><b>Frequency ; Modal Mass</b></p> $f = \frac{\alpha}{L^2} \sqrt{\frac{E t^3}{12 \cdot \mu (1 - \nu^2)}}; M_{\text{mod}} = \beta \cdot M_{\text{tot}}$
	 <p style="text-align: center;"><math>\beta \approx 0.18</math> for all <math>\lambda</math></p>
	 <p style="text-align: center;"><math>\beta \approx 0.22</math> for all <math>\lambda</math></p>
	 <p style="text-align: center;"><math>\beta \approx 0.21</math> for all <math>\lambda</math></p>

**Table 7-1 (continued): Natural frequencies and modal mass for isotropic plates**



<p><b>Supporting Conditions:</b></p> <p>  clamped     hinged </p>	<p><b>Frequency ; Modal Mass</b></p> $f = \frac{\alpha}{L^2} \sqrt{\frac{E t^3}{12 \cdot \mu (1 - \nu^2)}}; M_{\text{mod}} = \beta \cdot M_{\text{tot}}$
	 <p style="text-align: center;"><math>\beta \approx 0.17</math> for all <math>\lambda</math></p>
	<p><math>E</math>    Young's Modulus in N/m<sup>2</sup></p> <p><math>t</math>    Thickness of Plate in m</p> <p><math>\mu</math>    mass of floor including finishing and furniture in kg/m<sup>2</sup></p> <p><math>\nu</math>    Poisson ratio</p> <p><math>M_{\text{tot}}</math>    Total mass of floor including finishings and representative variable loading in kg</p>

**Table 7-1 (continued): Natural frequencies and modal mass for isotropic plates**

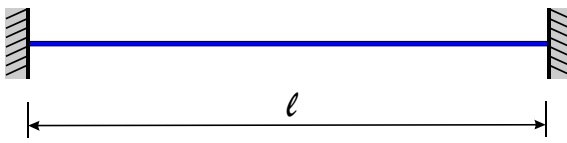
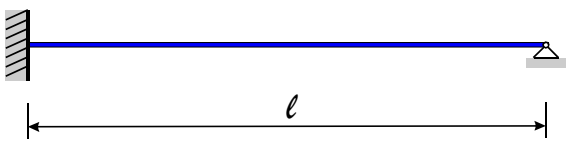
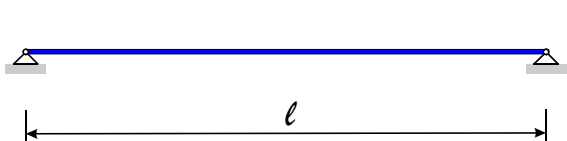
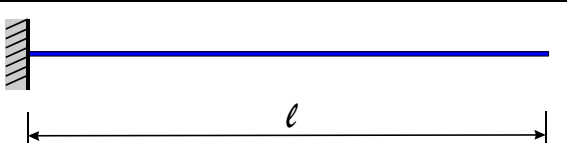
Supporting Conditions	Natural Frequency	Modal Mass
	$f = \frac{4}{\pi} \sqrt{\frac{3EI}{0.37\mu l^4}}$	$M_{\text{mod}} = 0,41 \mu l$
	$f = \frac{2}{\pi} \sqrt{\frac{3EI}{0.2\mu l^4}}$	$M_{\text{mod}} = 0,45 \mu l$
	$f = \frac{2}{\pi} \sqrt{\frac{3EI}{0.49 \mu l^4}}$	$M_{\text{mod}} = 0,5 \mu l$
	$f = \frac{1}{2\pi} \sqrt{\frac{3EI}{0.24\mu l^4}}$	$M_{\text{mod}} = 0,64 \mu l$

Table 7-2: Natural frequencies and modal mass for beams

### 7.4.2 Simple calculation methods for eigenfrequencies of orthotropic floors

Orthotropic floors as e.g. composite floors with beams in the longitudinal direction and a concrete plate in the transverse direction, see Figure 7-1, have different stiffness in length and width ( $EI_y > EI_x$ )

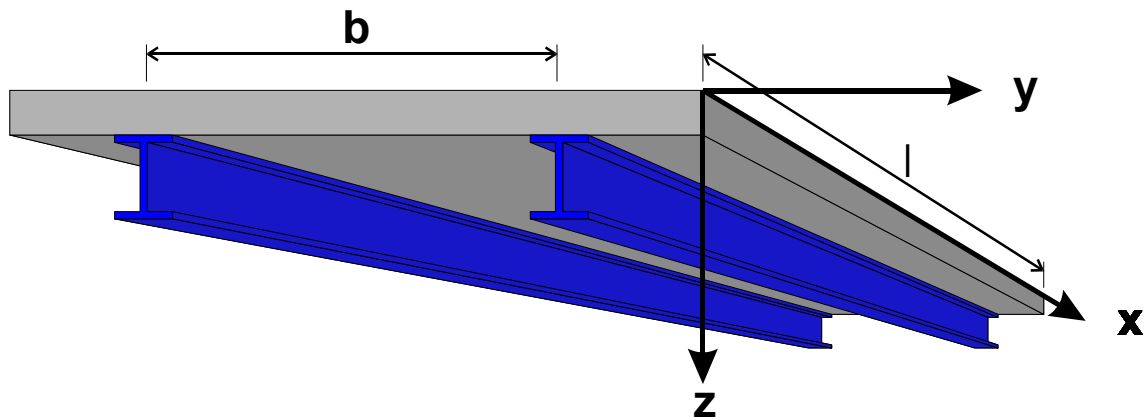


Figure 7-1: Dimensions and axis of an orthotropic plate

The first natural frequency of the orthotropic plate being simply supported at all four edges can be determined from

$$f_1 = \frac{\pi}{2} \sqrt{\frac{EI_y}{\mu l^4}} \sqrt{1 + \left[ 2 \left( \frac{b}{l} \right)^2 + \left( \frac{b}{l} \right)^4 \right] \frac{EI_x}{EI_y}}$$

where:

- $\mu$  is the mass per m<sup>2</sup> in kg/m<sup>2</sup>,
- $l$  is the length of the floor in m (in x-direction),
- $b$  is the width of the floor in m (in y-direction),
- $E$  is the Young's Modulus in N/m<sup>2</sup>,
- $I_x$  is the moment of inertia for bending about the x-axis in m<sup>4</sup>,
- $I_y$  is the moment of inertia for bending about the y-axis in m<sup>4</sup>.

### 7.4.3 Natural frequencies from the self-weight approach

The self-weight approach is a very practical approximation in cases where the maximum deflection  $\delta_{\max}$  due to self-weight loads has been determined, e.g. by finite element calculation.

The natural frequency may be obtained from

$$f = \frac{1}{2\pi} \sqrt{\frac{K}{M}} = \frac{1}{2\pi} \sqrt{\frac{4g}{3\delta_{\max}}} = \frac{18}{\sqrt{\delta_{\max} [mm]}}$$

where the following assumptions have been made:

$$K = \frac{M \cdot g}{\frac{3}{4} \delta_{\max}}$$

where:

$M$  is the total mass of the vibrating system,

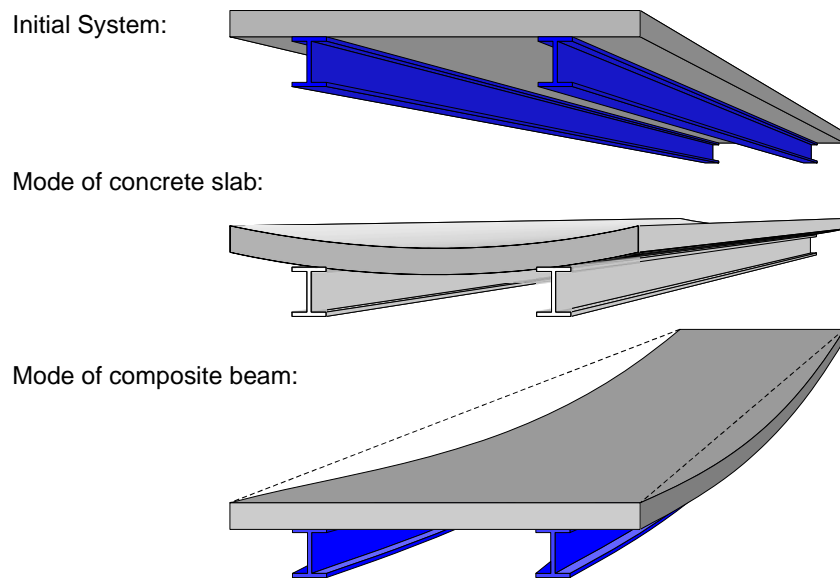
$g = 9.81 \frac{m}{s^2}$  is gravity and

$\frac{3}{4} \delta_{\max}$  is the average deflection.

#### 7.4.4 Natural frequency from the Dunkerley approach

The Dunkerley approach is an approximation for the case that the relevant mode shape is complex and can be considered as a superposition of simple modes, for which the natural frequencies can be determined, e.g. according to section 7.4.1 and 7.4.2.

**Figure 7-2** gives an example for a composite floor with two simply supported beams and a concrete plate without stiff supports.



**Figure 7-2: Example for mode shape decomposition**

The expected mode shape may be divided into a beam mode with the frequency  $f_1$  for the composite beam and a plate mode with the frequency  $f_2$  for the concrete slab.

The natural frequency accounting for the interaction of the beam mode and the plate mode would be

$$\frac{1}{f^2} = \frac{1}{f_1^2} + \frac{1}{f_2^2}$$

### 7.4.5 Modal mass from mode shape

Where an approximation of the mode shape by a normalized function  $\delta(x, y)$  with  $|\delta(x, y)|_{\max} = 1,0$  is available, e.g. from calculation of deflection due to a distribution of mass forces, see **Figure 7-3**, the modal mass may be obtained from:

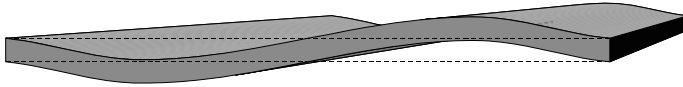
$$M_{\text{mod}} = \mu \int_F \delta^2(x, y) dF$$

where:

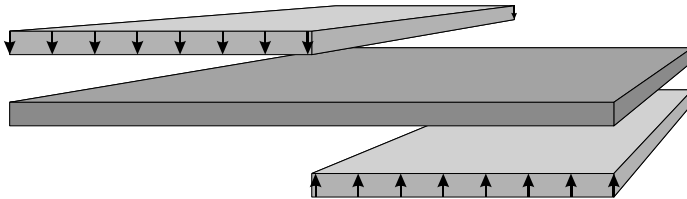
$\mu$  is the distribution of mass

$\delta(x, y)$  is the vertical deflection at location  $x, y$

**Expected mode shape:**



**Application of loads:**



**Figure 7-3: Example for the application of mass load distributions to obtain an approximation of mode shape**

In case of FEM calculations the modal mass results from:

$$M_{\text{mod}} = \sum_{\text{Nodes } i} \delta_i^2 \times dM_i$$

where:

$\delta_i$  is the vertical deflection at node  $i$  (normalised to the maximum deflection)

$dM_i$  is the mass attributed to the node  $i$  of the floor.

Examples for the use of these approximations, that in the case of exact solution for the mode shape give the exact modal mass, are given in **Table 7-3**.

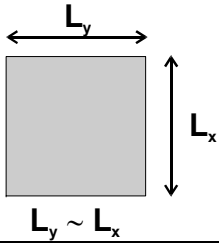
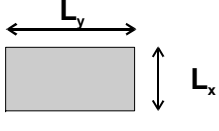
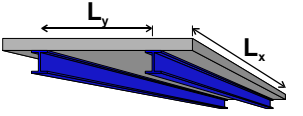
	Example	Approximation of mode shape	Mass distribution	Modal mass
1	 <p style="text-align: center;"><math>L_y \sim L_x</math></p>	$\delta(x, y) = \sin \frac{\pi x}{l_x} \sin \frac{\pi y}{l_y};  \delta(x, y) _{\max} = 1,0$	$\mu = \frac{M_{total}}{l_x \cdot l_y}$	$M_{mod} = \mu \int \delta^2(x, y) dF =$ $= \frac{M_{total}}{l_x l_y} \int_{l_y} \int_{l_x} \sin^2 \left( \frac{\pi x}{l_x} \right) \sin^2 \left( \frac{\pi y}{l_y} \right) dx dy = \frac{M_{total}}{4}$
2	 <p style="text-align: center;"><math>L_y \gg L_x</math></p>	<p>1. <math>0 \leq y \leq \frac{l_x}{2}</math> and <math>l_y - \frac{l_x}{2} \leq y \leq l_y</math></p> $\delta(x, y) = \sin \frac{\pi x}{l_x} \cdot \sin \frac{\pi y}{l_y};  \delta(x, y) _{\max} = 1,0$ <p>2. <math>\frac{l_x}{2} \leq y \leq l_y - \frac{l_x}{2}</math></p> $\delta(x, y) = \sin \frac{\pi x}{l_x} \cdot 1,0 \quad  \delta(x, y) _{\max} = 1,0$	$\mu = \frac{M_{total}}{l_x \cdot l_y}$	$M_{mod} = \mu \int \delta^2(x, y) dF =$ $= \frac{M_{total}}{l_x l_y} \left[ 2 \int_{l_y} \int_{l_x/2}^{\pi/2} \sin^2 \left( \frac{\pi x}{l_x} \right) \cdot \sin^2 \left( \frac{\pi y}{l_y} \right) dx dy + \int_{l_y} \int_{l_x/2}^{\pi/2} \sin^2 \left( \frac{\pi x}{l_x} \right) dx dy \right] = \frac{M_{total}}{4} \left( 2 - \frac{l_x}{l_y} \right)$
3	 <p>Plate and beams simply supported</p>	$\delta(x, y) = \frac{\delta_x}{\delta} \sin \frac{\pi x}{l_x} \sin \frac{\delta_y}{\delta} \sin \frac{\pi y}{l_y};  \delta(x, y) _{\max} = 1,0$ <p>where:  <math>\delta_x</math> = deflection of the beam  <math>\delta_y</math> = deflection of the slab      assuming stiff supports by the beams (<math>\delta_x = 0</math>)</p> $\delta = \delta_x + \delta_y$	$\mu = \frac{M_{total}}{l_x \cdot l_y}$	$M_{mod} = \mu \int \delta^2(x, y) dF =$ $= \frac{M_{total}}{l_x l_y} \int_{l_y} \int_{l_x} \left[ \frac{\delta_x}{\delta} \sin \frac{\pi x}{l_x} + \frac{\delta_y}{\delta} \sin \frac{\pi y}{l_y} \right]^2 dx dy$ $= M_{total} \cdot \left[ \frac{\delta_x^2 + \delta_y^2}{2\delta^2} + \frac{8}{\pi^2} \frac{\delta_x \cdot \delta_y}{\delta^2} \right]$

Table 7-3: Examples for the determination of modal mass by hand calculation

### 7.4.6 Eigenfrequencies and modal mass from FEM-analysis

Various FEM-programs can perform dynamic calculations and offer tools for the determination of natural frequencies. Many programs also calculate the modal mass automatically in the frequency analysis.

If FEM is applied for determining the dynamic properties for vibration, it should be considered that the FEM-model for this purpose may differ significantly from that used for ultimate limit state verification as only small deflections in the elastic range are expected.

A typical example is the selection of boundary conditions in vibration analysis compared with that for ULS design. A connection which is assumed to be hinged in ULS may be assumed to provide a full moment connection in the vibration analysis (due to initial stiffness).

## 7.5 Values for damping

Independently of the way of determining the natural frequency and modal mass, damping values for vibration systems can be determined using **Table 7-4** for different construction materials, furniture and finishing in the condition of use.

The system damping is obtained by summing up the appropriate values for  $D_1$  to  $D_3$ .

Type	Damping (% of critical damping)
Structural Damping $D_1$	
Wood	6%
Concrete	2%
Steel	1%
Composite	1%
Damping due to furniture $D_2$	
Traditional office for 1 to 3 persons with separation walls	2%
Paperless office	0%
Open plan office	1%
Library	1%
Houses	1%
Schools	0%
Gymnastic	0%
Damping due to finishings $D_3$	
Ceiling under the floor	1%
Free floating floor	0%
Swimming screed	1%
<b>Total Damping <math>D = D_1 + D_2 + D_3</math></b>	

**Table 7-4: Determination of damping**

## 7.6 Determination of the appropriate $OS-RM_{90}$ -value

When frequency and modal mass are determined, the  $OS-RMS_{90}$ -value can be obtained with the design charts given in **Figure 7-4** to **Figure 7-12**. The relevant diagram needs to be selected according to the damping characteristics of the floor.



The diagrams also contain an allocation of  $OS-RMS_{90}$  values to the floor classes.

In case various natural frequencies are relevant, the total (combined)  $OS-RMS_{90}$ -value may be determined from

$$OS - RMS_{90} = \sqrt{\sum_i (OS - RMS_{90})_i^2}$$

Classification based on a damping ratio of 1%

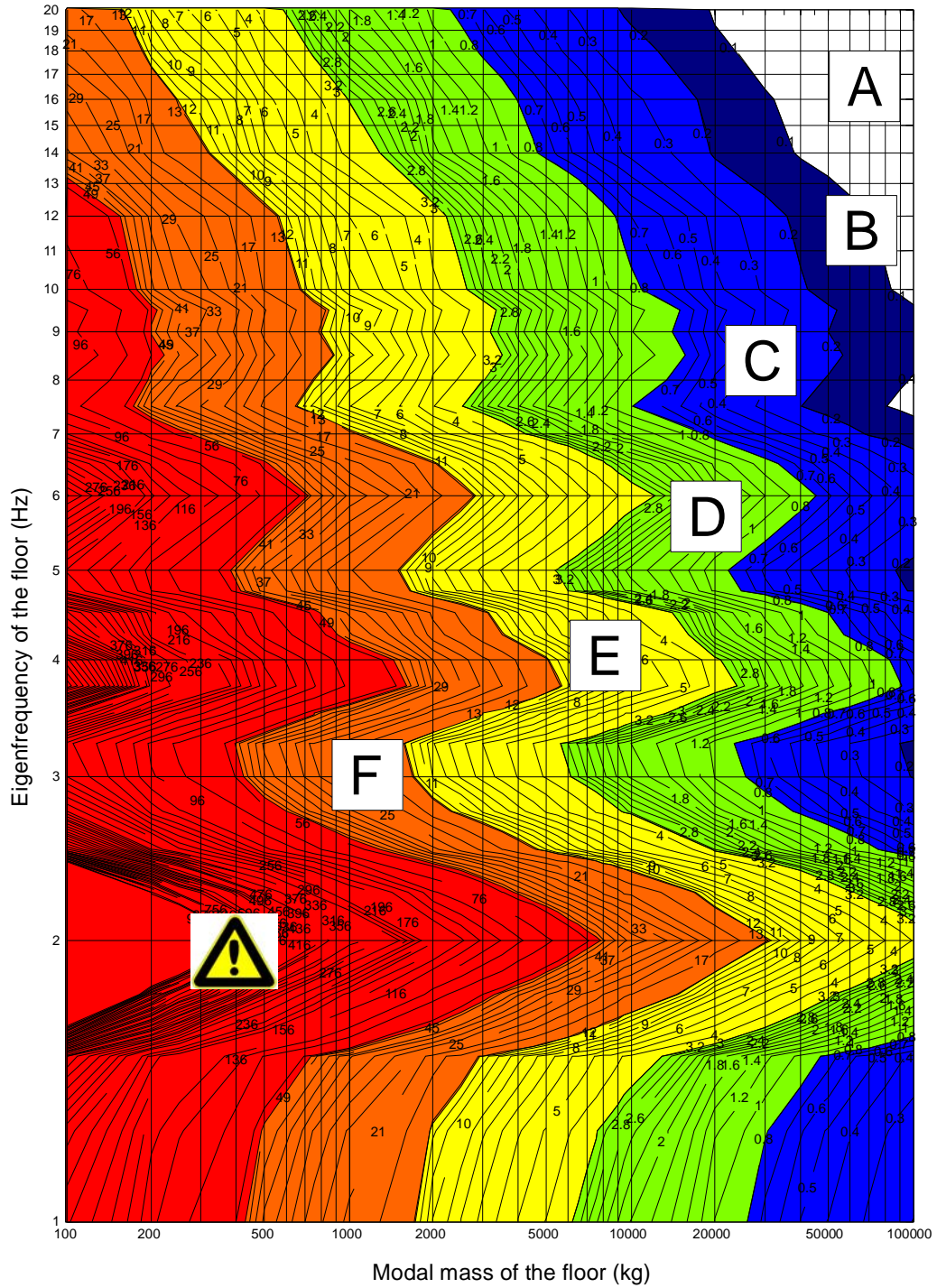


Figure 7-4: OS-RMS<sub>90</sub> for 1 % damping

Classification based on a damping ratio of 2%

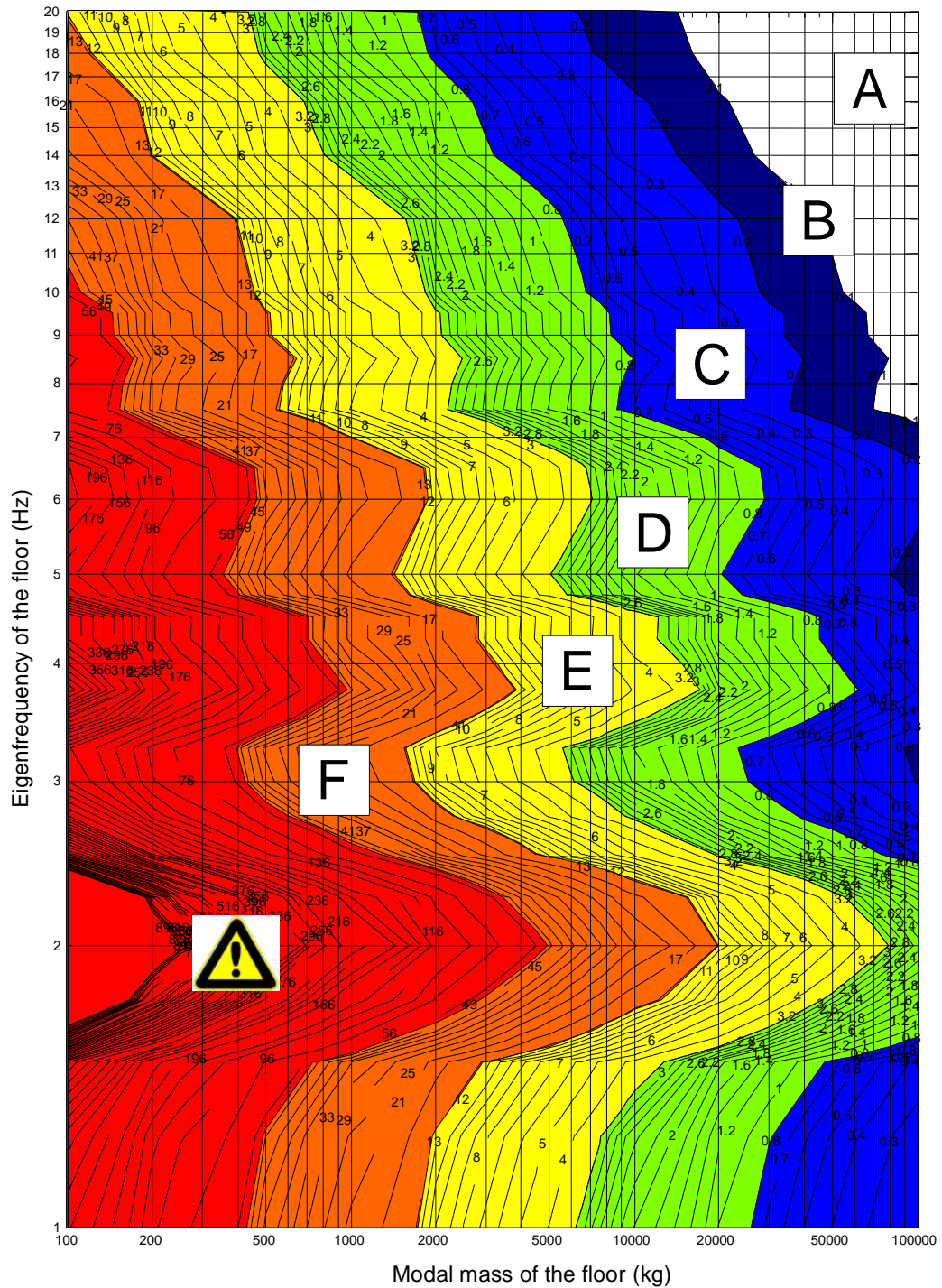


Figure 7-5:  $OS-RMS_{90}$  for 2 % damping

Classification based on a damping ratio of 3%

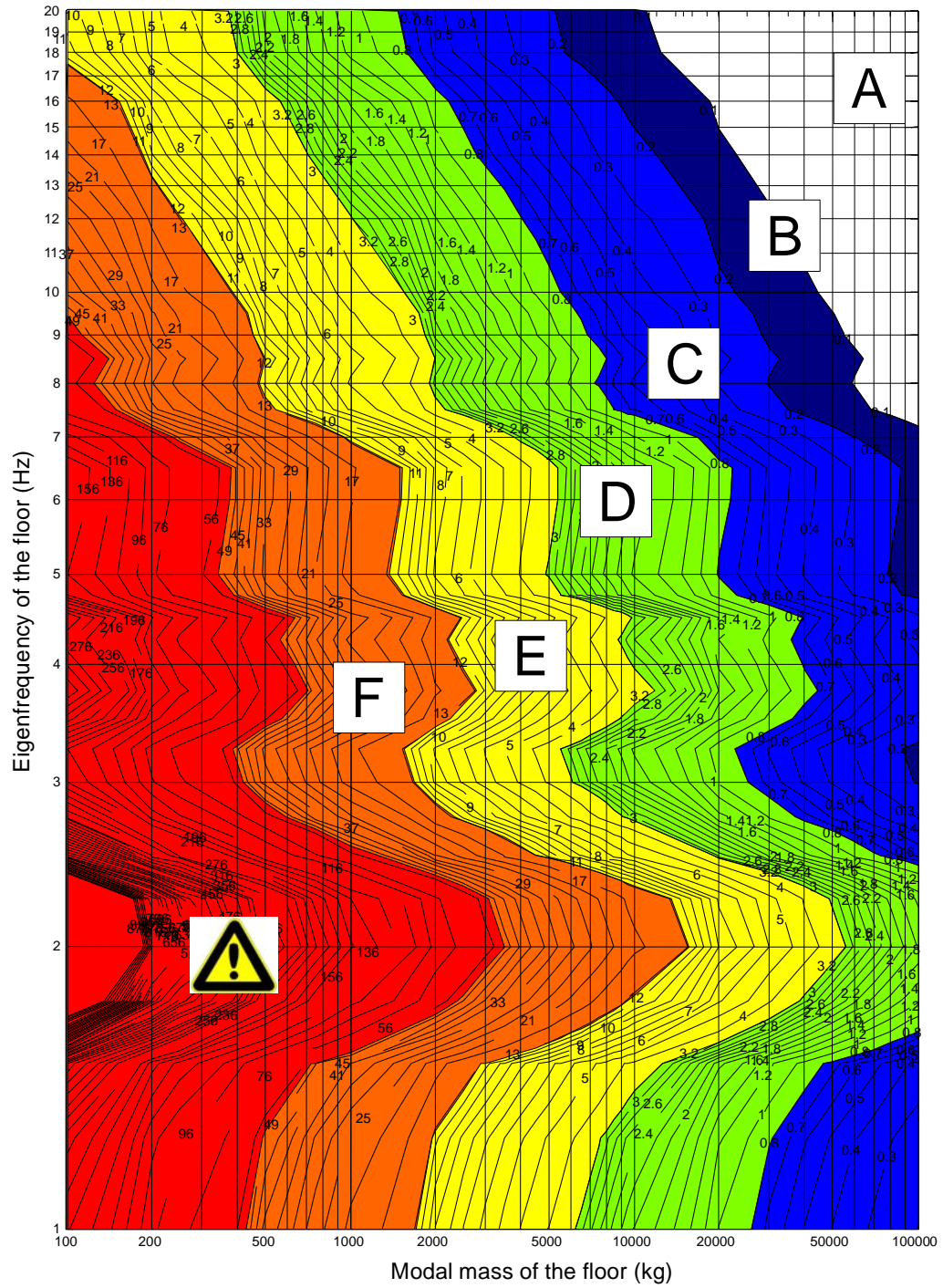
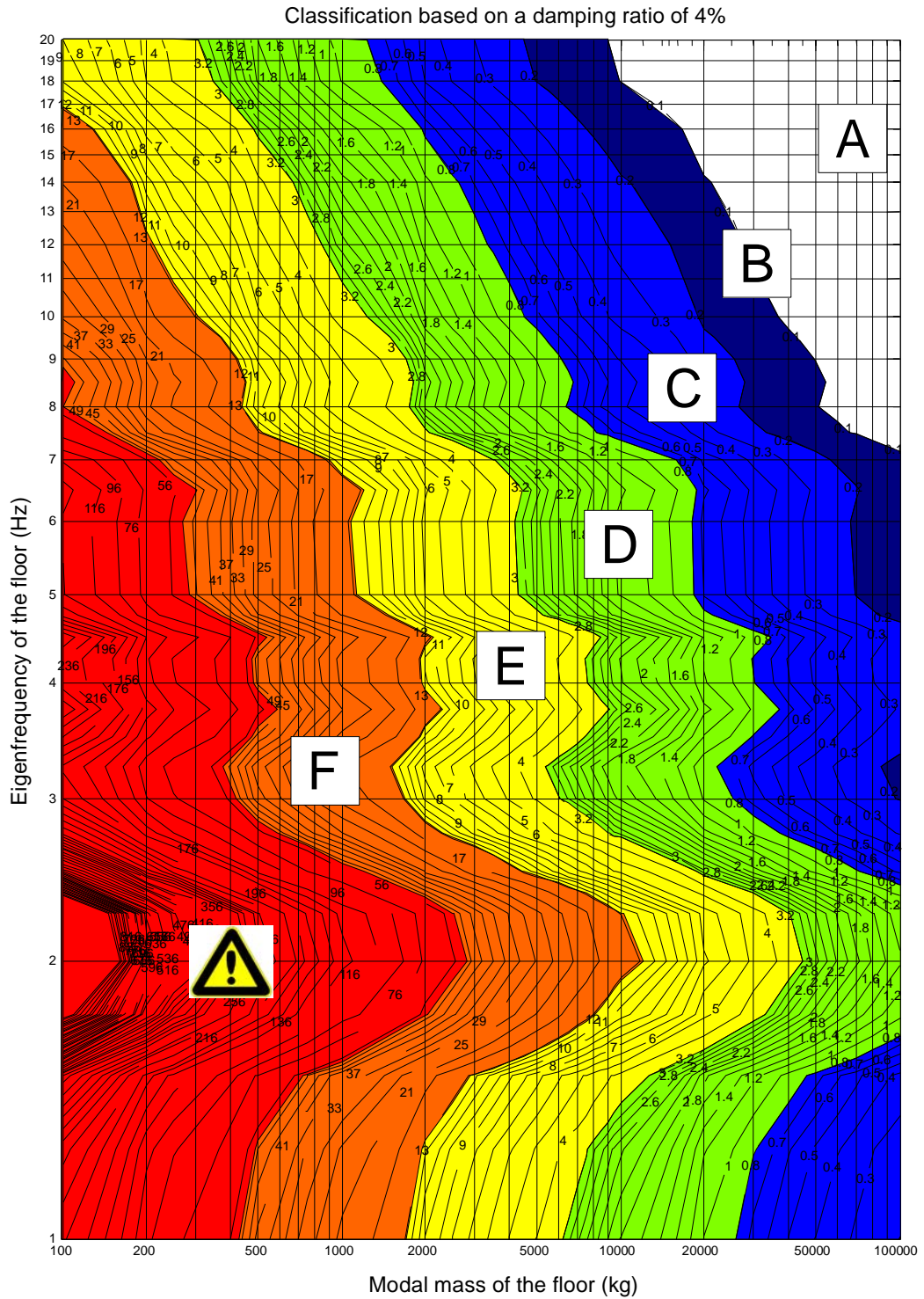


Figure 7-6: OS-RMS<sub>90</sub> for 3 % damping



**Figure 7-7: OS-RMS<sub>90</sub> for 4 % damping**

Classification based on a damping ratio of 5%

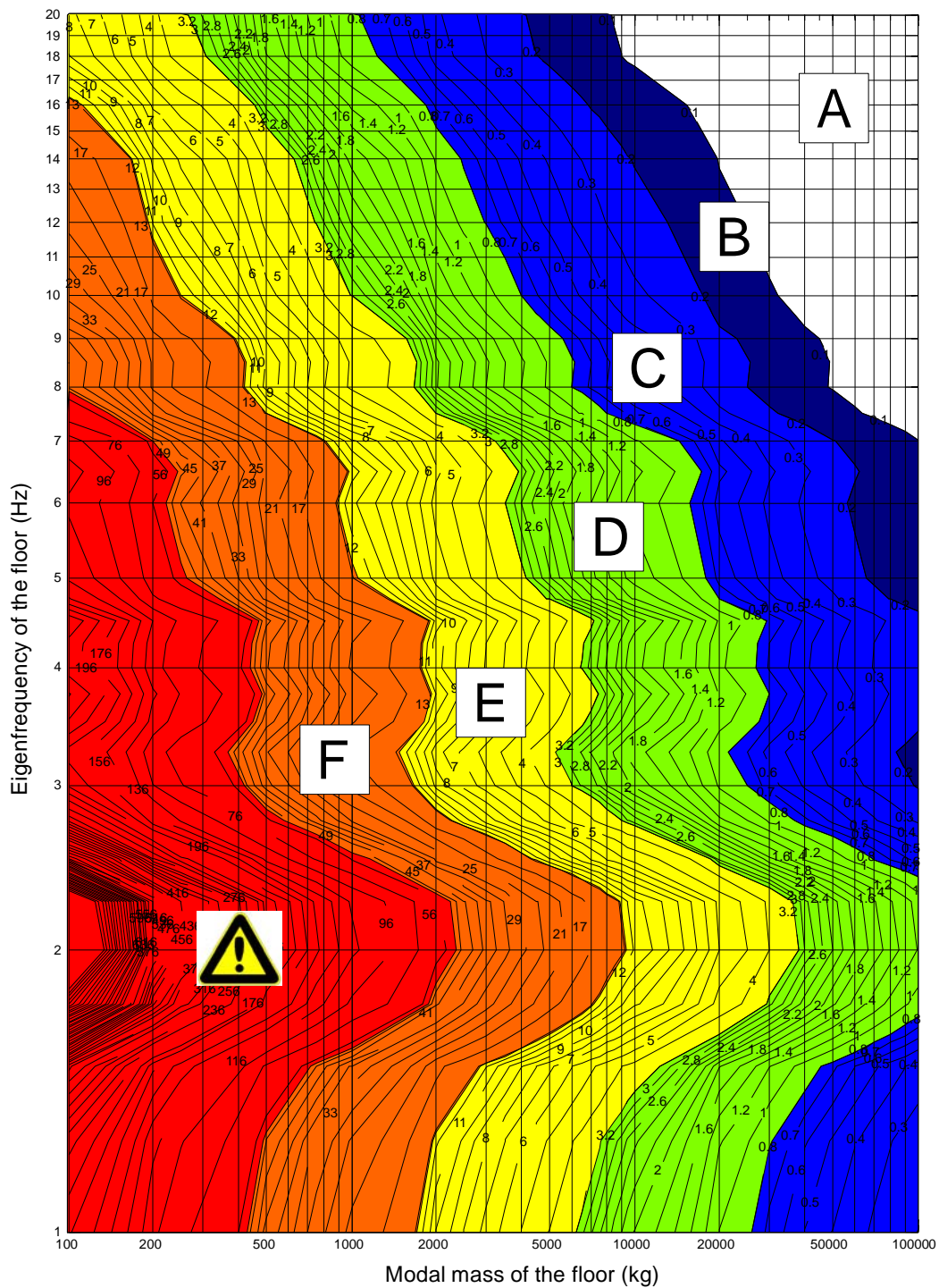


Figure 7-8: OS-RMS<sub>90</sub> for 5 % damping

Classification based on a damping ratio of 6%

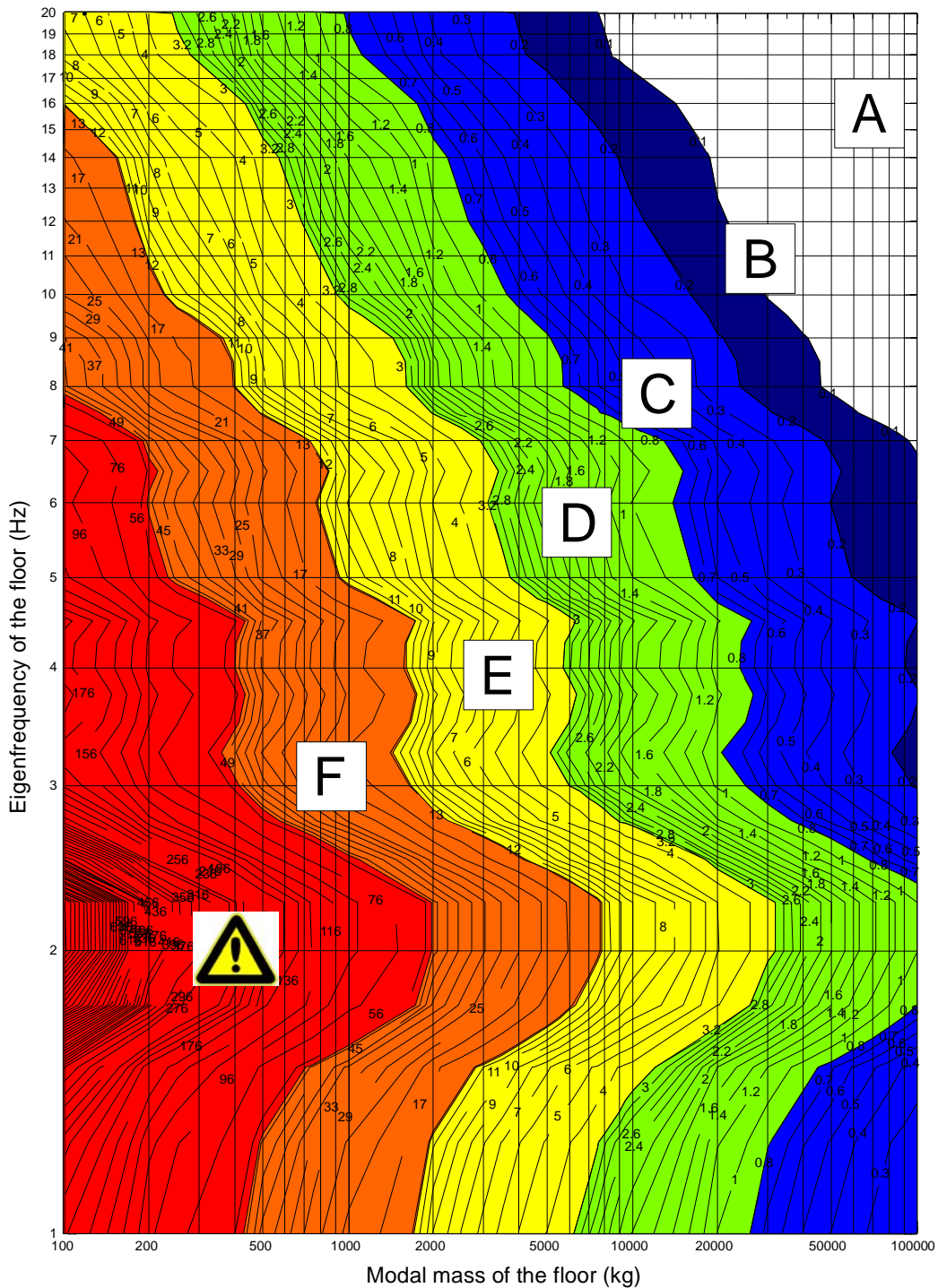


Figure 7-9: OS-RMS<sub>90</sub> for 6 % damping

Classification based on a damping ratio of 7%

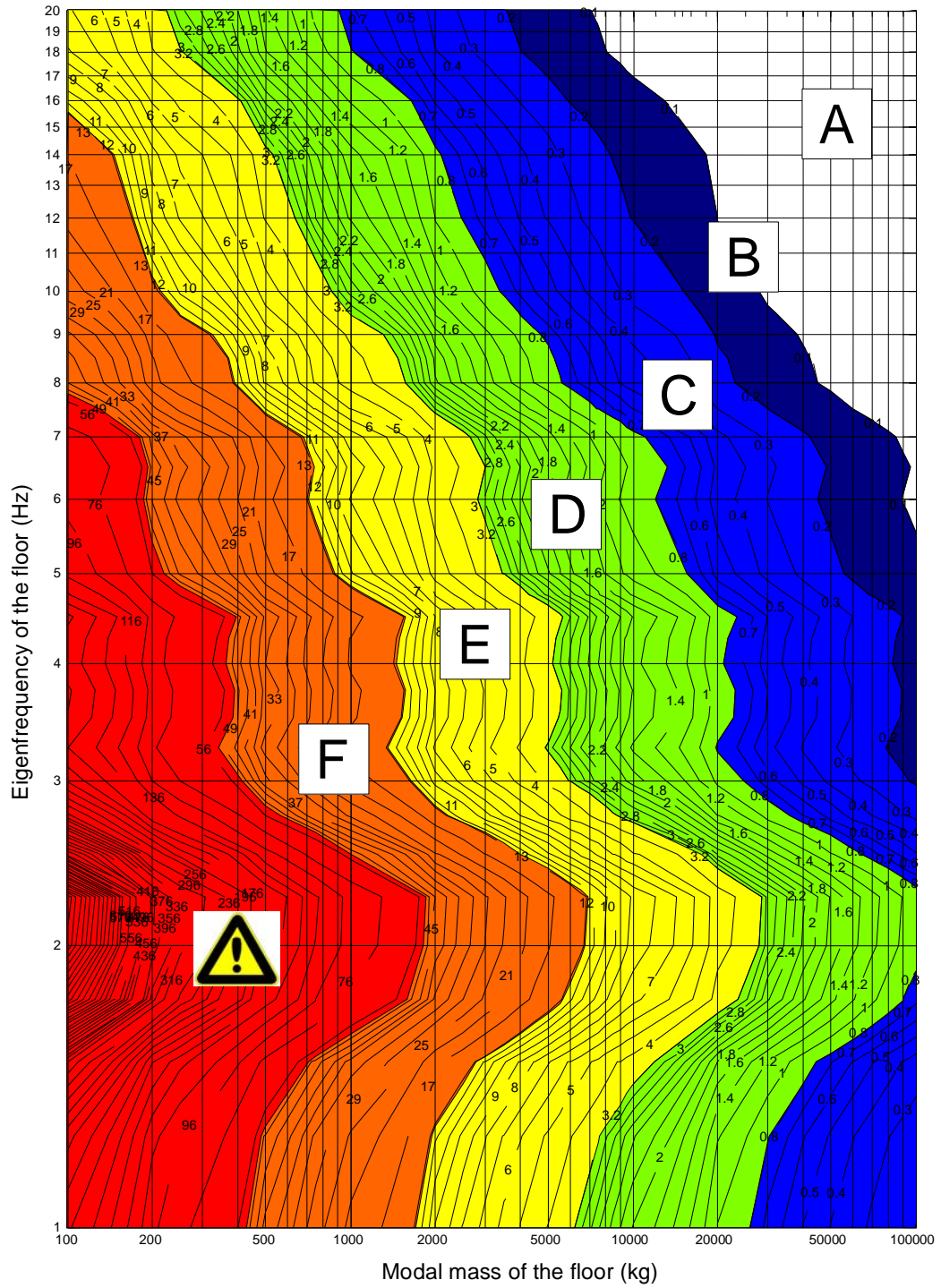


Figure 7-10: OS-RMS<sub>90</sub> for 7 % damping



Classification based on a damping ratio of 8%

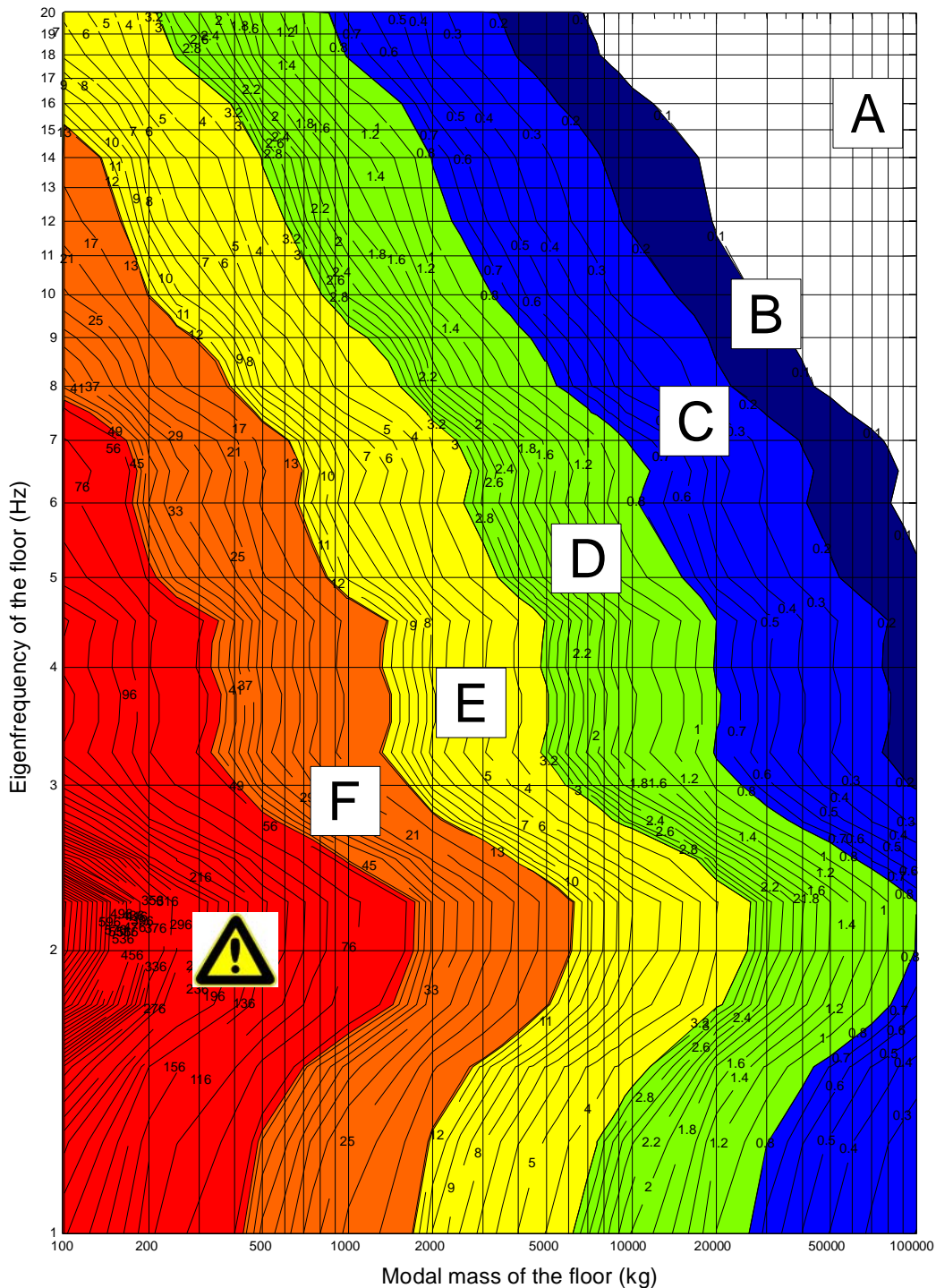


Figure 7-11: OS-RMS<sub>90</sub> for 8 % damping

Classification based on a damping ratio of 9%

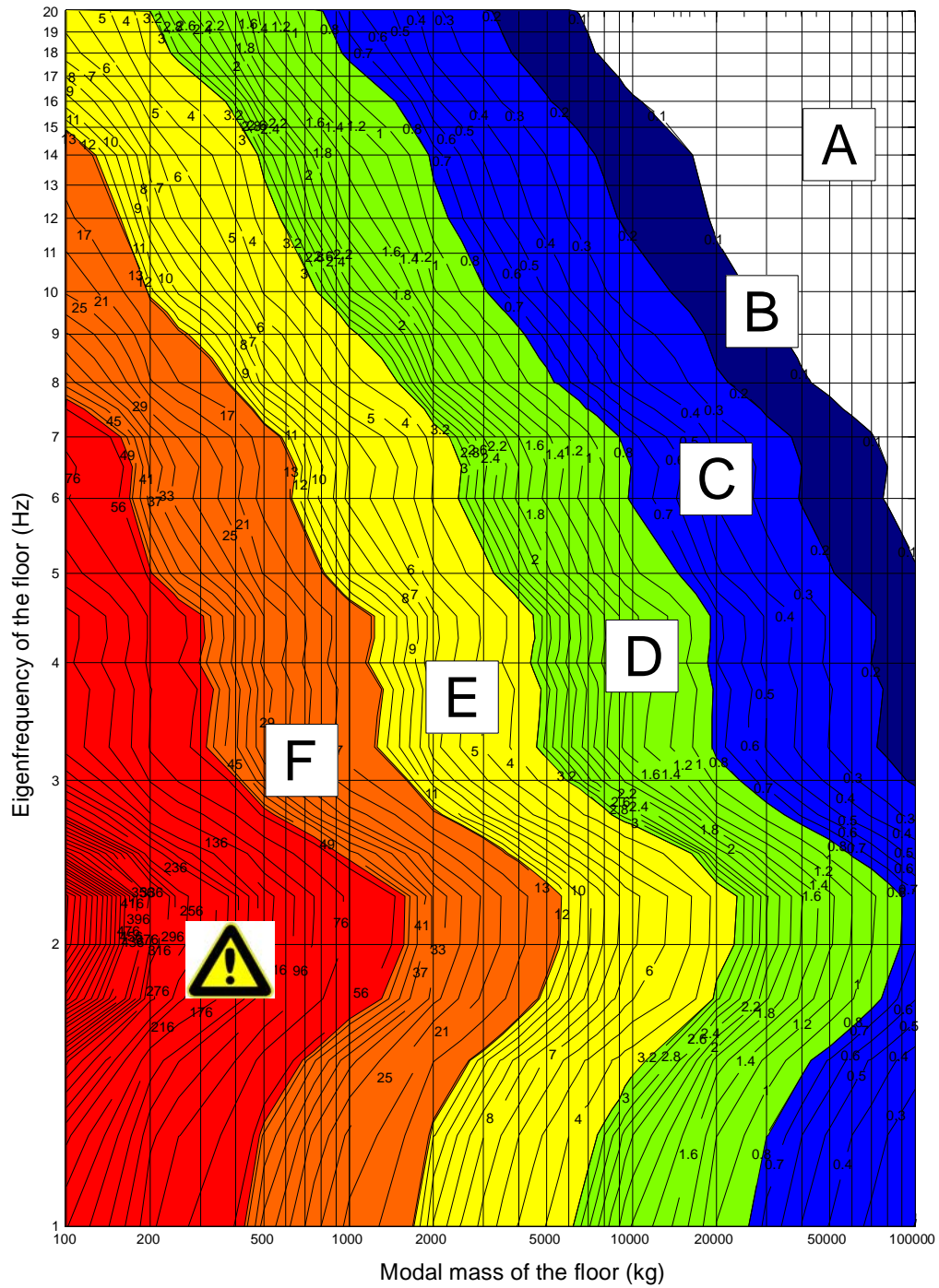


Figure 7-12: OS-RMS<sub>90</sub> for 9 % damping

## 7.7 Vibration performance assessment

In the serviceability assessment for the vibration performance, the performance requirement expressed in terms of floor-class according to **Table 7-5** should be compared with the performance capacity resulting from the  $OS-RMS_{90}$ -value in **Figure 7-4** to **Figure 7-12**.

The performance requirement as well as the use of this guidance should be agreed with the designer and the client.

Class	$OS-RMS_{90}$		Function of floor												
	Lower Limit	Upper Limit	Critical Workspace	Health	Education	Residential	Office	Meeting	Retail	Hotel	Prison	Industrial	Sport		
A	0.0	0.1	Recommended	Recommended	Recommended	Recommended	Recommended	Recommended	Recommended	Recommended	Recommended	Recommended	Recommended		
B	0.1	0.2	Critical	Recommended	Recommended	Recommended	Recommended	Recommended	Recommended	Recommended	Recommended	Recommended	Recommended		
C	0.2	0.8	Not recommended	Recommended	Recommended	Recommended	Recommended	Recommended	Recommended	Recommended	Recommended	Recommended	Recommended		
D	0.8	3.2	Not recommended	Critical	Critical	Recommended	Recommended	Recommended	Recommended	Recommended	Recommended	Recommended	Recommended		
E	3.2	12.8	Not recommended	Not recommended	Not recommended	Critical	Critical	Critical	Critical	Critical	Critical	Recommended	Recommended		
F	12.8	51.2	Not recommended	Not recommended	Not recommended	Not recommended	Not recommended	Not recommended	Not recommended	Not recommended	Not recommended	Critical	Critical		



Recommended

Critical

Not recommended

**Table 7-5: Recommendations for performance requirements**

## 8 Design examples

### 8.1 Filigree slab with ACB-composite beams (office building)

#### 8.1.1 Description of the floor

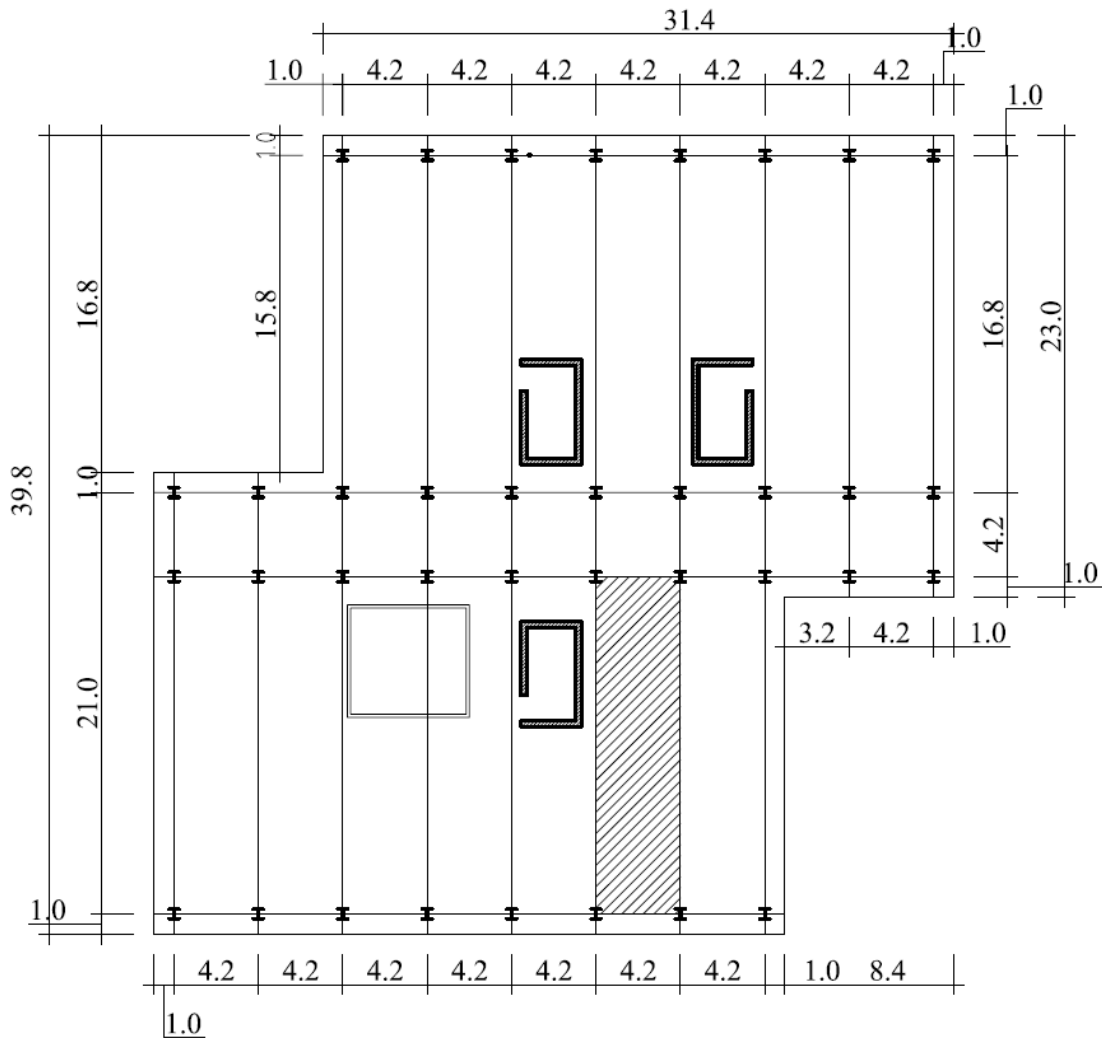
In the first worked example a filigree slab with false-floor in an open plan office is checked for footfall induced vibrations.



**Figure 8-1: Building structure**

It is spanning one way over 4.2 m between main beams. Its overall thickness is 160 mm. The main beams are Arcelor Cellular Beams (ACB) which act as composite beams. They are attached to the vertical columns by a full moment connection. The floor plan is shown in **Figure 8-2**. In **Figure 8-2** the part of the

floor which will be considered for the vibration analysis is indicated by the hatched area.



**Figure 8-2: Floor plan (dimensions in [m])**

For the main beams with a span of 16.8 m ACB/HEM400 profiles made of material S460 have been used. The main beams with the shorter span of 4.2 m are ACB/HEM360 made of S460.

The cross beams which are spanning in global x-direction may be neglected for the further calculations, as they do not contribute to the load transfer of the structure.

The nominal material properties are

- Steel S460:  $E_s = 210\,000\text{ N/mm}^2$ ,  $f_y = 460\text{ N/mm}^2$
- Concrete C25/30:  $E_{cm} = 31\,000\text{ N/mm}^2$ ,  $f_{ck} = 25\text{ N/mm}^2$

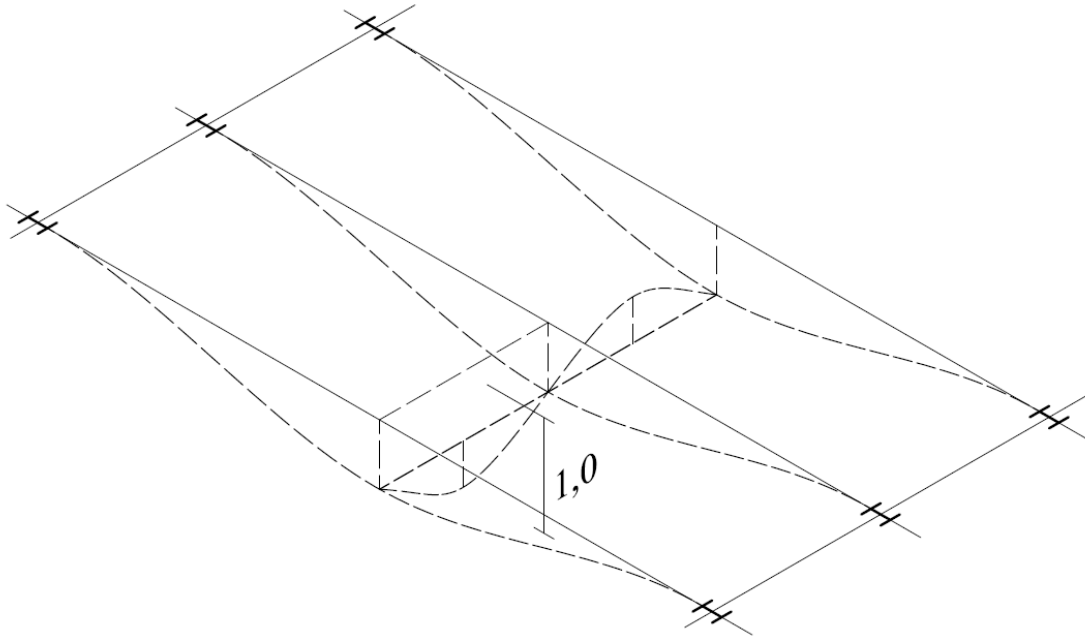
As required in section 7 of these guidance the nominal Elastic modulus of the concrete will be increased for the dynamic calculations:

$$E_{c,dyn} = 1.1 \times E_{cm} = 34100 \text{ N} / \text{mm}^2$$

The expected mode shape of the part of the floor considered which corresponds to the first eigenfrequency is shown in **Figure 8-4**. From the mode shape it can be concluded that each field of the concrete slab may be assumed to be simply supported for the further dynamic calculations. Regarding the boundary conditions of the main beams (see beam to column connection, Figure 8-3), it is assumed that for small amplitudes as they occur in vibration analysis the beam-column connection provides sufficient rotational restraint, so that the main beams may be considered to be fully clamped.



**Figure 8-3: Beam to column connection**



**Figure 8-4: Mode shape expected for the part of the floor considered corresponding to the first eigenfrequency**

### Section properties

- Slab:

The relevant section properties of the slab in global x-direction are:

$$A_{c,x} = 160 \frac{mm^2}{mm}$$

$$I_{c,x} = 3.41 \times 10^5 \frac{mm^4}{mm}$$

- Main beam:

Assuming the first vibration mode described above the effective width of the composite beam may be obtained from the following equation:

$$b_{eff} = b_{eff,1} + b_{eff,2} = \frac{l_0}{8} + \frac{l_0}{8} = 2 \times \frac{0.7 \times 16.8}{8} = 2.94 m$$

The relevant section properties of the main beam for serviceability limit state (no cracking) are:

$$A_{a,netto} = 21936 mm^2$$

$$A_{a,brutto} = 29214 mm^2$$

$$A_i = 98320 mm^2$$

$$I_i = 5.149 \times 10^9 \text{ mm}^4$$

### Loads

- Slab:

- Self-weight (includes 1.0 kN/m<sup>2</sup> for false floor):

$$g_{slab} = 160 \times 10^{-3} \times 25 + 1.0 = 5 \frac{\text{kN}}{\text{m}^2}$$

- Live load: Usually a characteristic live load of 3 kN/m<sup>2</sup> is recommended for floors in office buildings. The fraction of the live load considered for the dynamic calculation is assumed to be approx. 10% of the full live load, i.e. for the vibration check it is assumed that

$$q_{slab} = 0.1 \times 3.0 = 0.3 \frac{\text{kN}}{\text{m}^2}$$

- Main beam:

- Self-weight (includes 2.00 kN/m for ACB):

$$g_{beam} = 5.0 \times \frac{4.2}{2} \times 2 + 2.0 = 23.00 \frac{\text{kN}}{\text{m}}$$

- Live load:

$$q_{slab} = 0.3 \times \frac{4.2}{2} \times 2 = 1.26 \frac{\text{kN}}{\text{m}}$$

## 8.1.2 Determination of dynamic floor characteristics

### Eigenfrequency

The first eigenfrequency is calculated on the basis of the self-weight approach. The maximum total deflection may be obtained by superposition of the deflection of the slab and the deflection of the main beam, i.e.

$$\delta_{total} = \delta_{slab} + \delta_{beam}$$

with

$$\delta_{slab} = \frac{5 \times (5.0 + 0.3) \times 10^{-3} \times 4200^4}{384 \times 34100 \times 3.41 \times 10^5} = 1.9 \text{ mm}$$



$$\delta_{beam} = \frac{1 \times (23.0 + 1,26) \times 16800^4}{384 \times 210000 \times 5.149 \times 10^9} = 4.5mm$$

The total deflection is

$$\delta_{total} = 1.9 + 4.5 = 6.4mm$$

Thus, the first eigenfrequency may be obtained from the self-weight approach (section 7.4.3):

$$f_1 = \frac{18}{\sqrt{6.4}} = 7.1Hz$$

### **Modal mass**

The total mass of the slab is

$$M_{total} = (5 + 0.3) \times 10^2 \times 16.8 \times 4.2 = 37397kg$$

According to Table 7-3, example 3, the modal mass of the slab considered may be calculated as

$$M_{mod} = 37397 \times \left[ \frac{1.9^2 + 4.5^2}{2 \times 6.4^2} + \frac{8}{\pi^2} \times \frac{1.9 \times 4.5}{6.4^2} \right] = 17220kg$$

### **Damping**

The damping ratio of the steel-concrete slab with false floor is determined according to **Table 7-4**:

$$D = D_1 + D_2 + D_3 = +1\% + 1\% + 1\% = 3\%$$

with

$D_1 = 1.0 \%$  (composite slab)

$D_2 = 1.0 \%$  (open plan office)

$D_3 = 1.0 \%$  (false floor)

### 8.1.3 Assessment

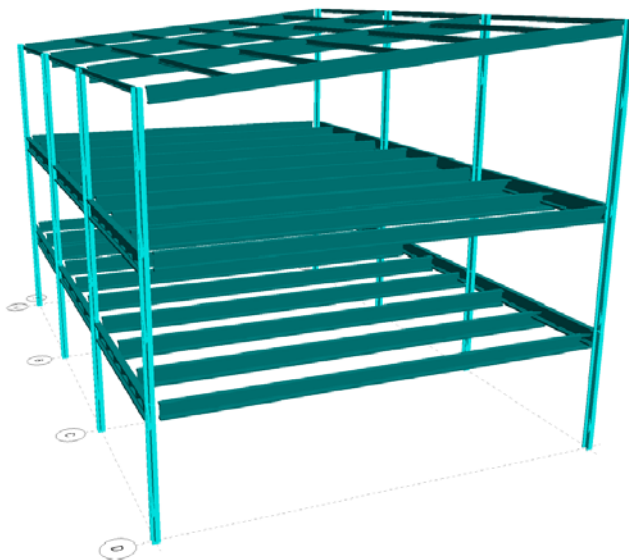
Based on the modal properties calculated above, the floor is classified as class C (**Figure 7-6**). The expected  $OS-RMS_{90}$  value is approx. 0.5 mm/s.

According to **Table 7-5** class C is classified as being suitable for office buildings, i.e. the requirements are fulfilled.

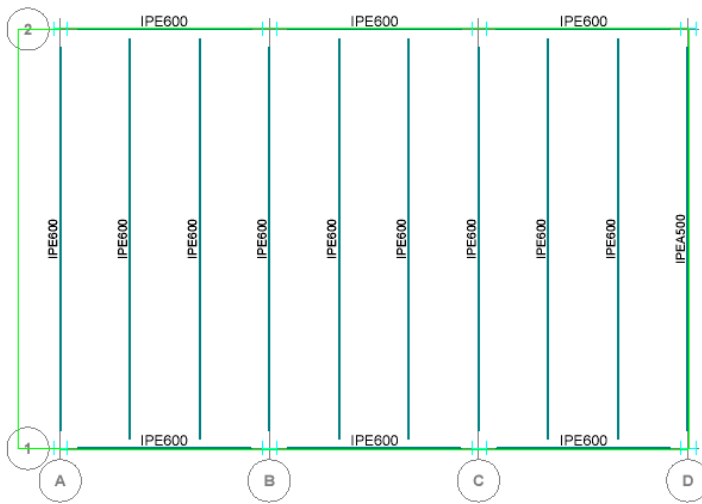
## 8.2 Three storey office building

### 8.2.1 Description of the floor

The floor of this office building, **Figure 8-5**, has a span of 15 m from edge beam to edge beam. In the regular area these secondary floor beams have IPE600 sections and are laying in a distance of 2.5 m. Primary edge beam which span 7.5 m from column to column have also IPE600 sections, see **Figure 8-6**.

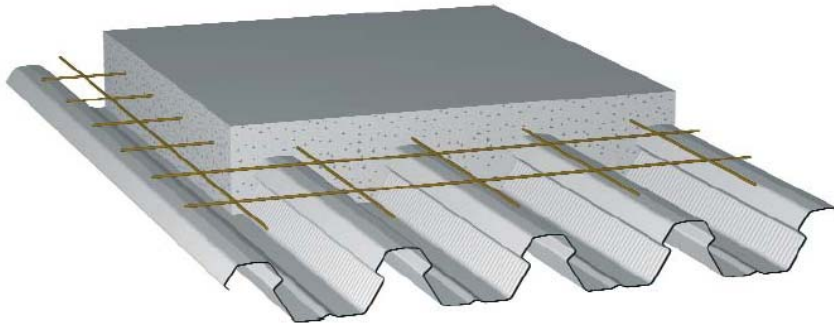


**Figure 8-5: Building overview**



**Figure 8-6: Steel section of the floor**

The floor is a composite plate with steel sheets COFRASTRA 70 with a total thickness of 15 cm, as represented in Figure 8-7.



**Figure 8-7: Floor set up**

The nominal material properties are:

- Steel S235:  $E_s = 210\,000\text{ N/mm}^2$ ,  $f_y = 235\text{ N/mm}^2$
  - Concrete C25/30:  $E_{cm} = 31\,000\text{ N/mm}^2$ ,  $f_{ck} = 25\text{ N/mm}^2$
- $$E_{c,dyn} = 1.1 \times E_{cm} = 34100\text{ N/mm}^2$$

### **Section properties**

- Slab (transversal to beam):
  - $A = 1170 \text{ cm}^2/\text{m}$
  - $I = 20\,355 \text{ cm}^4/\text{m}$
  - $g = 3.5 \text{ kN/m}^2$
  - $\Delta g = 0.5 \text{ kN/m}^2$
  
- Composite beam ( $b_{eff} = 2,5\text{m}$ ;  $E=210000 \text{ N/mm}^2$ ):
  - $A = 468 \text{ cm}^2$
  - $I = 270\,089 \text{ cm}^4$
  - $g = (3.5+0.5) \times 2.5 + 1.22 = 11.22 \text{ kN/m}$

### **Loads**

- Slab (transversal to beam):
  - $g + \Delta g = 4.0 \text{ kN/m}^2$  (permanent load)
  - $q = 3.0 \times 0.1 = 0.3 \text{ kN/m}^2$  (10% of full live load)
  - $p_{total} = 4.3 \text{ kN/m}^2$
  
- Composite beam ( $b_{eff} = 2.5\text{m}$ ;  $E=210000 \text{ N/mm}^2$ ):
  - $g = 11.22 \text{ kN/m}$
  - $q = 0.3 \times 2.5 = 0.75 \text{ kN/m}$
  - $p_{total} = 11.97 \text{ kN/m}$

## 8.2.2 Determination of dynamic floor characteristics

### **Supporting conditions**

The secondary beams are connected to the primary beams which have open sections with low torsional stiffness. Thus these beams may be assumed to be simple supported.

### **Eigenfrequency**

For this example the supporting conditions are determined in two ways.

The first method is the application of the beam formula neglecting the transversal stiffness of the floor.

The second method is the self-weight method considering the transversal stiffness.

- Application of the beam equation (Table 7.2):

$$p = 11.97 \text{ [kN / m]} \Rightarrow \mu = 11.97 \times 1000 \text{ [kg m / s}^2 \text{ / m]} / 9.81 \text{ [m / s}^2 \text{]} = 1220 \text{ [kg / m]}$$

$$f = \frac{2}{\pi} \sqrt{\frac{3EI}{0.49 \mu l^4}} = \frac{2}{\pi} \sqrt{\frac{3 \times 210000 \times 10^6 \text{ [N / m}^2 \text{]} \times 270089 \times 10^{-8} \text{ [m}^4 \text{]}}{0.49 \times 1220 \text{ [kg / m]} \times 15^4 \text{ [m}^4 \text{]}}} = 4.77 \text{ Hz}$$

- Application of the equation for orthotropic plates (section 7.4.2):

$$f_1 = \frac{\pi}{2} \sqrt{\frac{EI_y}{\mu l^4}} \sqrt{1 + \left[ 2 \left( \frac{b}{l} \right)^2 + \left( \frac{b}{l} \right)^4 \right] \frac{EI_x}{EI_y}}$$

$$= \frac{\pi}{2} \sqrt{\frac{210000 \times 10^6 \times 270089 \times 10^{-8}}{1220 \times 15^4}} \sqrt{1 + \left[ 2 \left( \frac{2.5}{15} \right)^2 + \left( \frac{2.5}{15} \right)^4 \right] \frac{3410 \times 20355}{21000 \times 270089}}$$

$$= 4.76 \times 1.00 = 4.76 \text{ Hz}$$

- Application of the self-weight approach (section 7.4.3):

$$\delta_{total} = \delta_{slab} + \delta_{beam}$$

$$\delta_{slab} = \frac{5 \times 4.3 \times 10^{-3} \times 2500^4}{384 \times 34100 \times 2.0355 \times 10^5} = 0.3 \text{ mm}$$

$$\delta_{beam} = \frac{5 \times 11.97 \times 15000^4}{384 \times 210000 \times 270089 \times 10^4} = 13.9 \text{ mm}$$

$$\delta_{total} = 0.3 + 13.9 = 14.2 \text{ mm}$$

$$\Rightarrow f_1 = \frac{18}{\sqrt{14.2}} = 4.78 \text{ Hz}$$

### **Modal mass**

The determination of the eigenfrequency, as presented above, shows that the load bearing behaviour of the floor can be approximated by a simple beam

model. Thus, this model is taken for the determination of the modal mass; see **Figure 7-2:**

$$M_{\text{mod}} = 0,5 \mu l = 0,5 \times 1220 \times 15 = 9150 \text{ kg}$$

### **Damping**

The damping ratio of the steel-concrete slab with false floor is determined according to **Table 7-4:**

$$D = D_1 + D_2 + D_3 = +1\% + 1\% + 1\% = 3\%$$

with

$$D_1 = 1.0 \text{ \% (composite slab)}$$

$$D_2 = 1.0 \text{ \% (open plan office)}$$

$$D_3 = 1.0 \text{ \% (ceiling under floor)}$$

### 8.2.3 Assessment

Based on the modal properties calculated above, the floor is classified as class D (**Figure 7-6**). The expected  $OS-RMS_{90}$  value is approx. 3.2 mm/s.

According to **Table 7-5** class D is classified as being suitable for office buildings, i.e. the requirements are fulfilled.

## 9 References

- [1] G. Sedlacek, Chr. Heinemeyer, Chr. Butz, B. Völling, S. Hicks, P. Waarts, F. van Duin, T. Demarco: "Generalisation of criteria for floor vibrations for industrial, office and public buildings and gymnastic halls - VOF", RFCS Report EUR 21972 EN, 2006, ISBN 92-76-01705-5, <http://europa.eu.int>.
- [2] M. Feldmann, Chr. Heinemeyer, E. Caetano, A. Cunha, F. Galant, A. Goldack, O. Hechler, S. Hicks, A. Keil, M. Lukic, R. Obiala, M. Schlaich, A. Smith, P. Waarts: RFCS-Project: "Human induced Vibration of Steel Structures – HIVOSS": Design Guideline and Background Report" Internet: <http://ww.stb.rwth-aachen.de/projekte/2007/HIVOSS/HIVOSS.html>.
- [3] H. Bachmann, W. Amman: "Vibration of Structures induced by Man and Machines" IABSE-AIPC-IVBH, Zürich, ISBN 3-85748-052-X, 1987.
- [4] Waarts, P. "Trillingen van vloeren door lopen: Richtlijn voor het voorspellen, meten en beoordelen", SBR, September 2005.
- [5] A. Smith, S. Hicks, P. Devine: "Design of Floors for Vibration: A new Approach", SCI-Publication P354, ISBN 10:1-85942-176-8, ISBN 13:978-1-85942-176-5, 2007.
- [6] ISO/DIS 10137: "Basis for design of structures – Serviceability of buildings and walkways against vibrations", International Organisation for Standardisation, 2007.
- [7] ISO 2631-1: Mechanical vibration and shock - Evaluation of human exposure to whole body vibration; Part 1: General requirements, 1997 International Organisation for Standardisation.
- [8] ISO 2631-2: Mechanical vibration and shock - Evaluation of human exposure to whole body vibration: Part 2. Vibration in buildings (1 Hz-80 Hz), April 2003.
- [9] Verein Deutscher Ingenieure: "VDI-Richtlinie 2057: Einwirkungen mechanischer Schwingungen auf den Menschen", VDI-Verlag GmbH, Düsseldorf, 2002.
- [10] NS 8176 E "Vibration and shock – Measurement of vibration in buildings from land based transports and guidance to evaluation of its effect on human beings", Standards Norway (1999, 2005).
- [11] DIN 4150 "Erschütterungen im Bauwesen – Teil 2: Einwirkungen auf Menschen in Gebäuden", June 1999.



European Commission

**EUR 24084 EN** – Joint Research Centre – Institute for the Protection and Security of the Citizen

Title: **Design of floor structures for human induced vibrations**

Author(s): M. Feldmann, Ch. Heinemeyer, Chr. Butz, E. Caetano, A. Cunha, F. Galanti, A. Goldack, O. Hechler, S. Hicks, A. Keil, M. Lukic, R. Obiala, M. Schlaich, G. Sedlacek, A. Smith, P. Waarts

Luxembourg: Office for Official Publications of the European Communities

2009 – 64 pp. – 21 x 29.7 cm

EUR – Scientific and Technical Research series – ISSN 1018-5593

ISBN 978-92-79-14094-5

DOI 10.2788/4640

### **Abstract**

In recent years, the introduction of new structural materials and innovative construction processes, associated to architectural and space arrangement requirements, in multi-storey buildings construction have produced significantly more flexible floor structural systems. The design of these floor systems is usually controlled by serviceability criteria, deflections or vibrations. Recognizing a gap in the design codes, this report gives a procedure for the determination and assessment of floor response for human induced vibrations.

First, the proposed procedure is presented, giving particular attention to the human induced loading characterization, dynamic properties and the comfort criteria for the verification of floor structural systems. Design charts are derived. Finally, it is presented a guidance manual to use the simplified procedure proposed for the design of building floors for human induced vibrations. Two worked examples of the proposed design procedure are given, namely a filigree slab with ACB-composite beams and a composite slab with steel beams.

*Keywords:* Floor structures; Design procedures; Human induced vibrations; Structural safety; Human comfort; Dynamic properties; Vibration control

### **How to obtain EU publications**

Our priced publications are available from EU Bookshop (<http://bookshop.europa.eu>), where you can place an order with the sales agent of your choice.

The Publications Office has a worldwide network of sales agents. You can obtain their contact details by sending a fax to (352) 29 29-42758.

The mission of the JRC is to provide customer-driven scientific and technical support for the conception, development, implementation and monitoring of EU policies. As a service of the European Commission, the JRC functions as a reference centre of science and technology for the Union. Close to the policy-making process, it serves the common interest of the Member States, while being independent of special interests, whether private or national.



The European Convention for Constructional Steelwork (ECCS) is the federation of the National Association of Steelwork industries and covers a worldwide network of Industrial Companies, Universities and research Institutes.

