

Fire resistance assessment of composite steel-concrete structures

Basic design methods
Worked examples

CAJOT Louis-Guy

CEN/TC250 EG-EN1994-1-2 Convenor
ArcelorMittal

email: lg.cajot@arcelormittal.com

Basic design methods of EN1994-1-2

Fire part of Eurocode 4

Following common layout to provide design rules for fire resistance of various types of structures:

»»» General

- Scope, application field, definitions, symbols and units

»»» Basic principles

- Performances requirements, design values of material properties and assessment approaches

»»» Material properties

- Mechanical and thermal properties at elevated temperatures

»»» Assessment methods for fire resistance

»»» Constructional details

»»» Annexes

- Additional information: common case - more detailed design rules

Load bearing function **R** of composite structures is covered by the design rules of the fire part of Eurocode 4

- Load bearing function of a structure is satisfied only if during the relevant of fire exposure **t**

$$E_{fi,d,t} \leq R_{fi,d,t}$$

where

E_{fi,d,t} : design effect of actions (Eurocodes 0 and 1)

R_{fi,d,t} : corresponding design resistance of the structure at instant **t**

- In addition, for elements ensuring compartmentation, the separating function has to be maintained during the relevant fire exposure **t**
 - Integrity **E**
 - Thermal insulation **I**

- E** - Integrity separating function
- I** - Thermal insulation separating function

I:
Calculated temperature
rise under standard fire
 ≤ 140 K

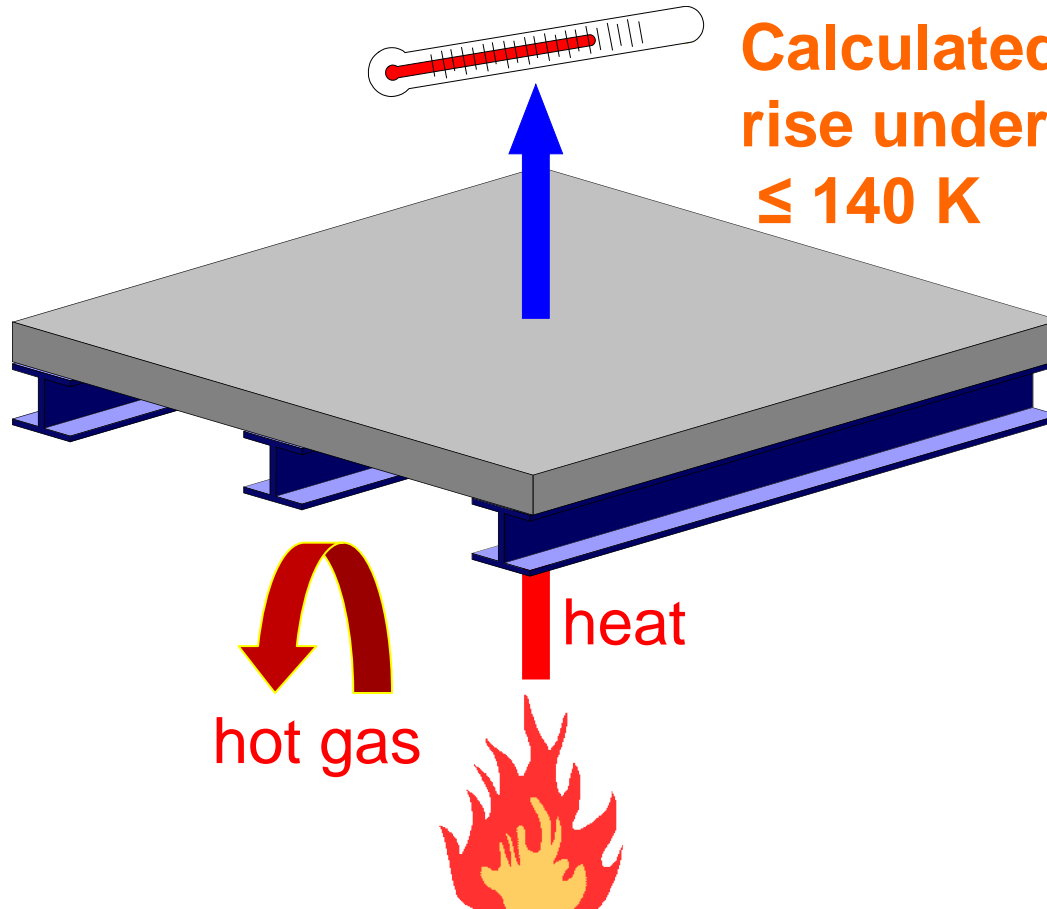

E assumed to be satisfied for composite slabs

Covered field

- Composite elements designed according to EN1994-1-1
- Longitudinal shear connection between steel and concrete in accordance with EN1994-1-1 or verified by tests
- Typical elements

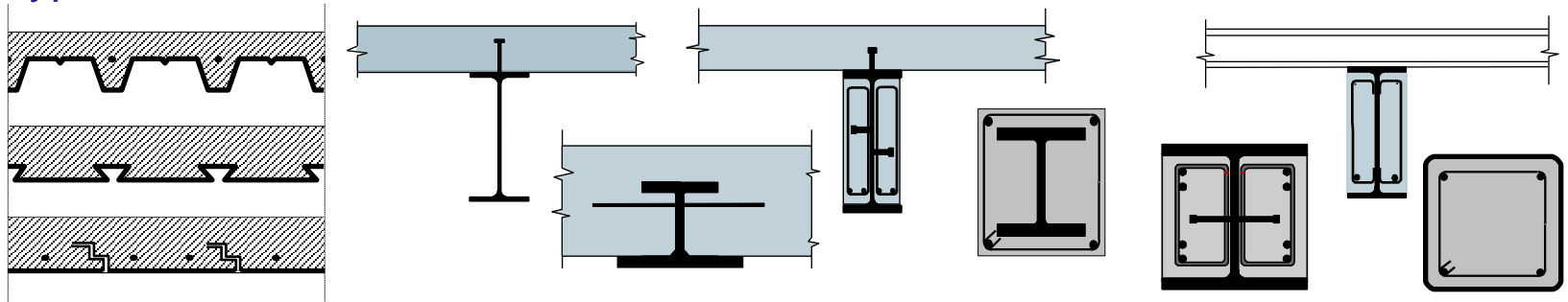

- Steel grades S235, S275, S355, S420 & S460 of EN10025, EN10210-1 and EN10219-1
- Profiled steel sheeting following 3.5 of EN1994-1-1
- Rebars in accordance with EN10080
- Concrete in accordance with EN1994-1-1 except < C20/25 and LC20/22 and > C50/60 and LC50/55

Actions on structures exposed to fire

- Thermal actions
- Mechanical actions
- Load level in fire situation

Eurocodes 0 and 1

Design approaches

- Member analysis
- Analysis of parts of the structure
- Global structural analysis

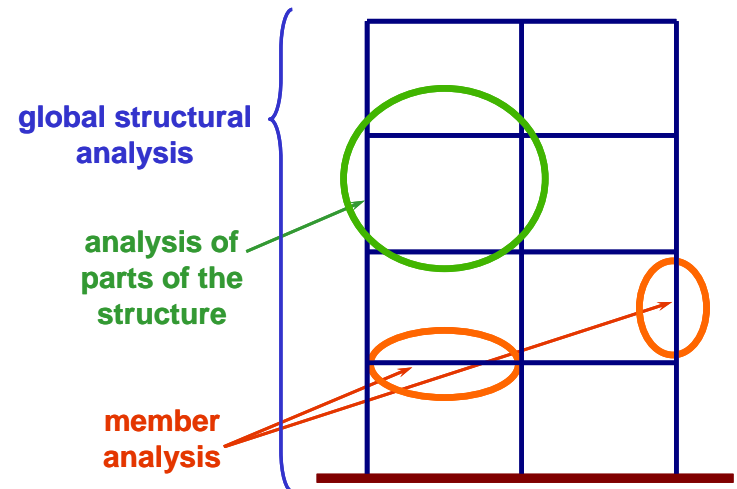

Material properties at elevated temperatures

- Thermal properties of steel and concrete
- Mechanical properties of steel (sections, rebars) and concrete
- Partial factors for fire design of steel structures

Application of EC4 for fire resistance assessment – basic knowledge

Application domain of different design methods for composite structures under fire situation

- ❑ Thermal action defined under standard fire

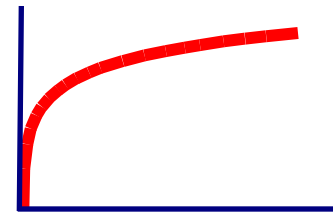

Type of analysis	Tabulated Data	Simple calculation methods		Advanced calculation models
			Critical temperature	
Member analysis	YES	YES	YES	YES
Analysis of parts of the structure	NOT applicable	Applicable in some cases	NOT applicable	YES
Global structural analysis	NOT applicable	NOT applicable	NOT applicable	YES

Application of EC4 for fire resistance assessment – basic knowledge

Application domain of different design methods for composite structures under fire situation

Thermal action defined under natural fire

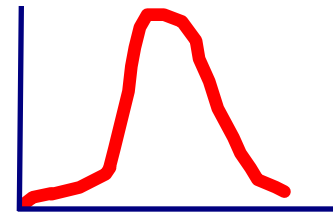

Type of analysis	Tabulated Data	Simple calculation methods		
			Critical temperature	Advanced calculation models
Member analysis	NOT applicable	Applicable with some specific conditions	YES	YES
Analysis of parts of the structure	NOT applicable		NOT applicable	YES
Global structural analysis	NOT applicable	NOT applicable	NOT applicable	YES

Application of EC4 for fire resistance assessment – basic knowledge

Thermal properties of steel and concrete at elevated temperatures

Thermal conductivity [W/m^{°K}]

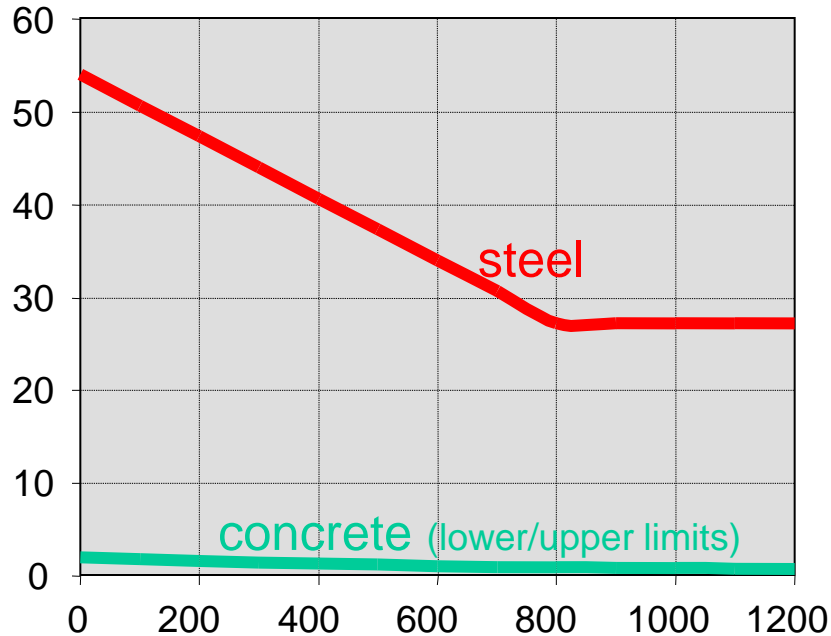

Temperature [°C]

Thermal capacity (ρc) [MJ/m³°K]

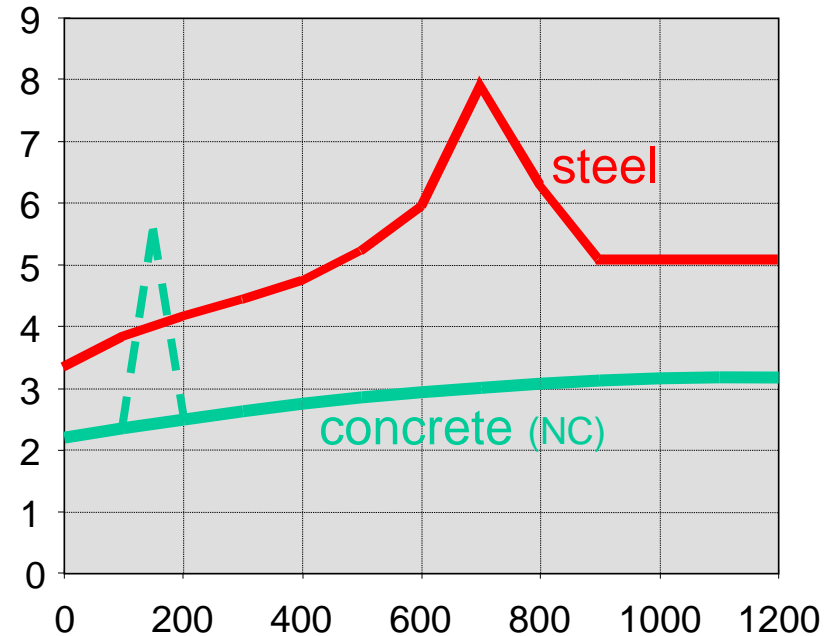

Temperature [°C]

Density of steel: 7850 kg/m³ ; Density of normal weight concrete: 2300 kg/m³

Thermal properties of concrete ONLY used in Advanced Calculation Models

Application of EC4 for fire resistance assessment – basic knowledge

Temperature field after 90 minutes of ISO-fire

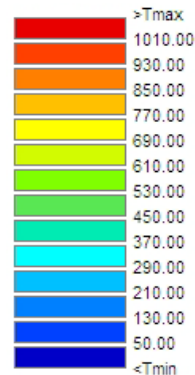
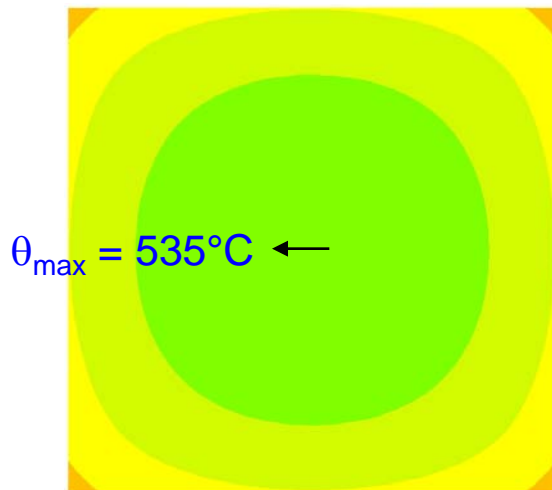
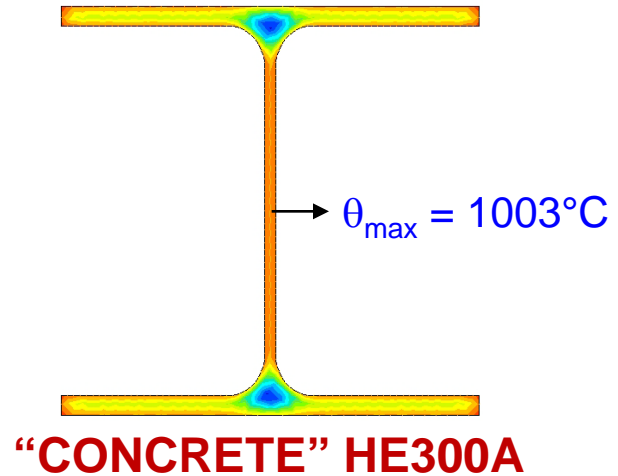
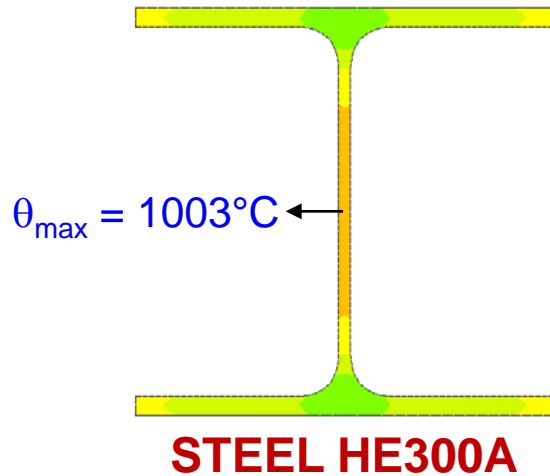

"STEEL" CONCRETE column

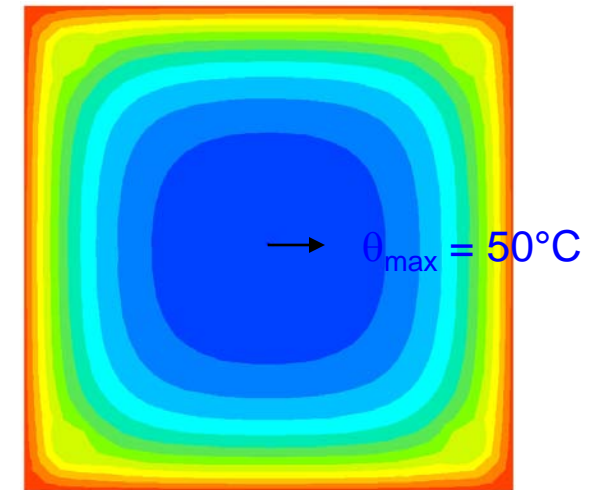

CONCRETE column

Thermal properties of steel and concrete at elevated temperatures

Thermal expansion of steel

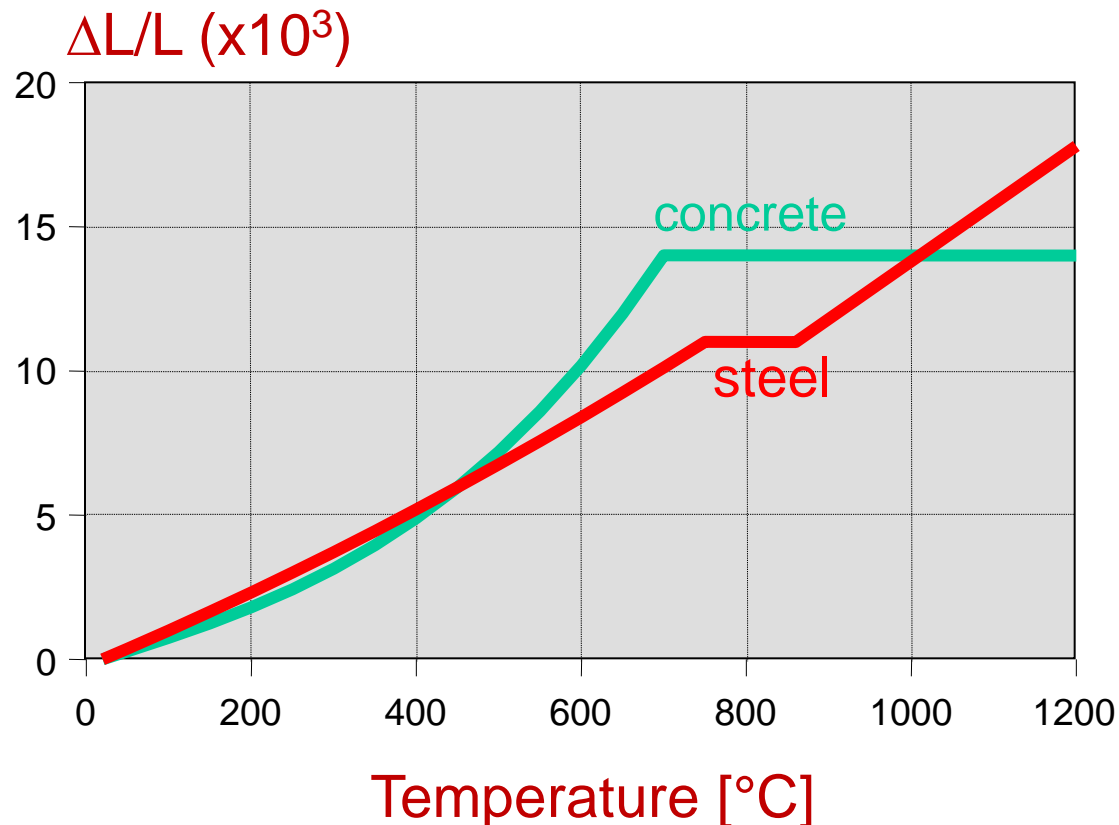

Mechanical properties of steel at elevated temperatures

Reduction factors

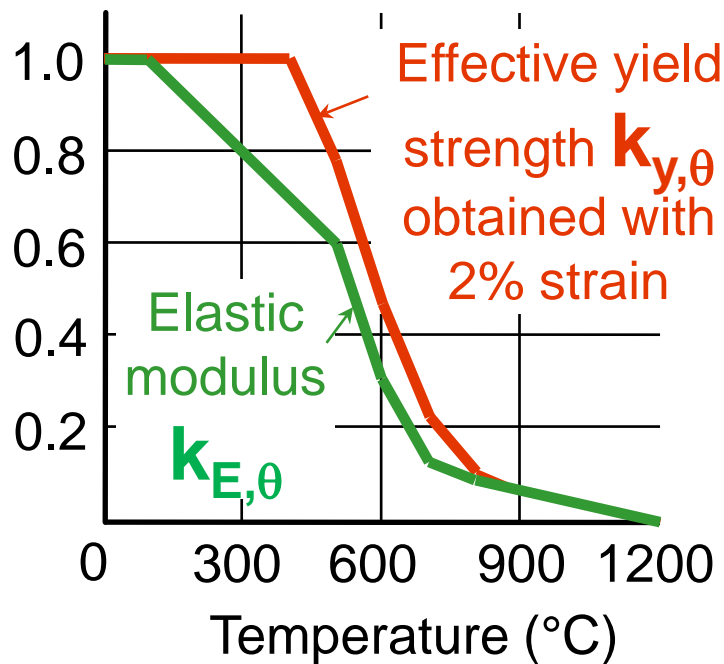

- ◆ Elastic modulus at 600°C reduced by about 70%

Normalised stress

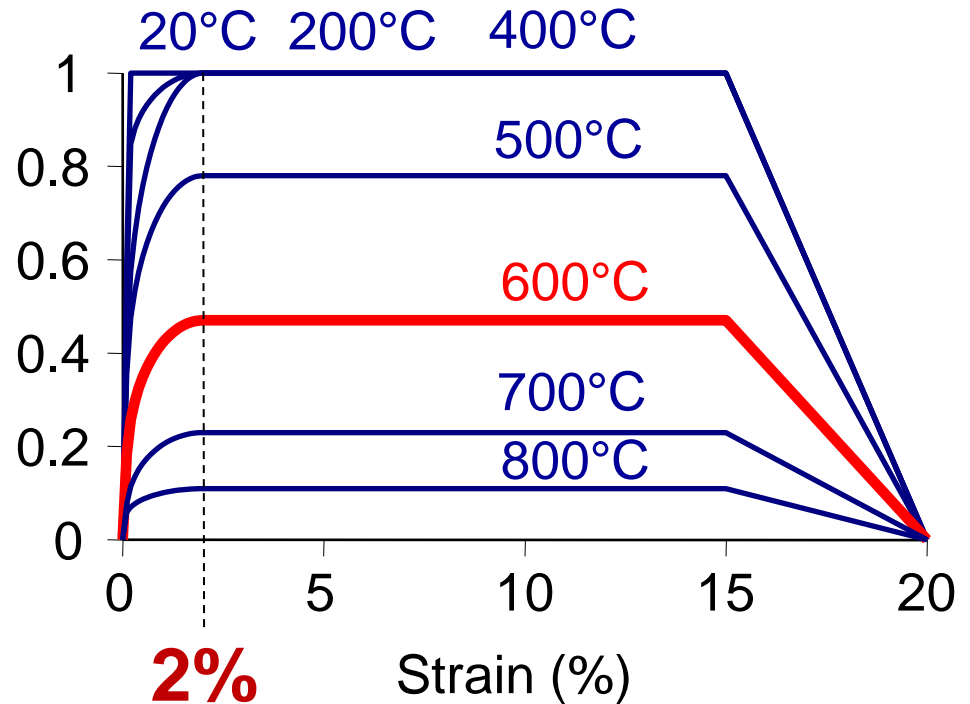

- ◆ Yield strength at 600°C reduced by over 50%

Mechanical properties of concrete at elevated temperatures

Strength

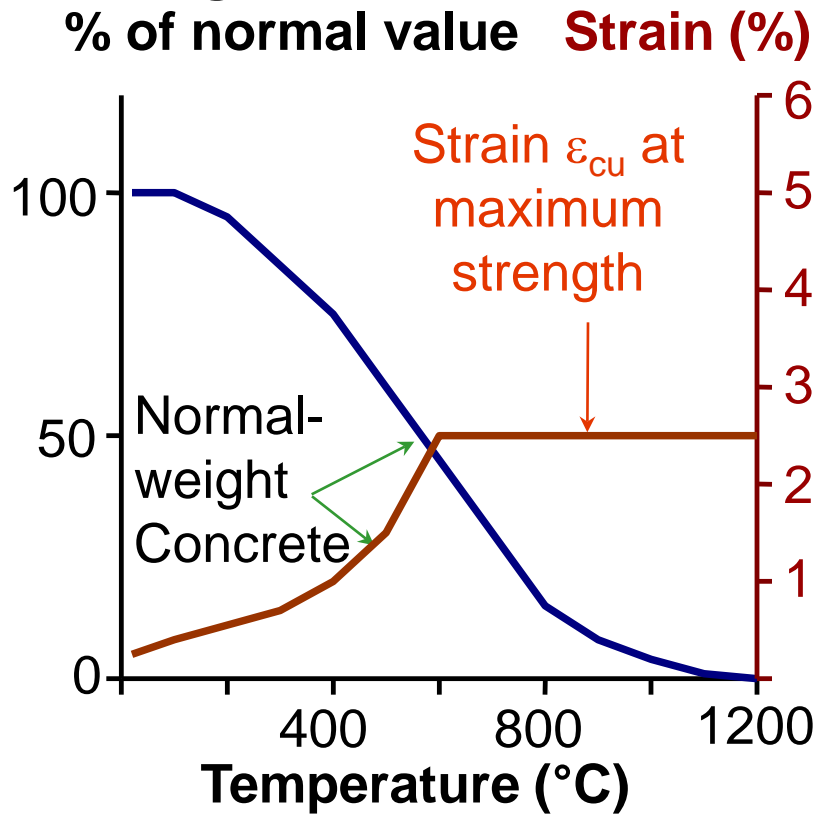

Normalised stress

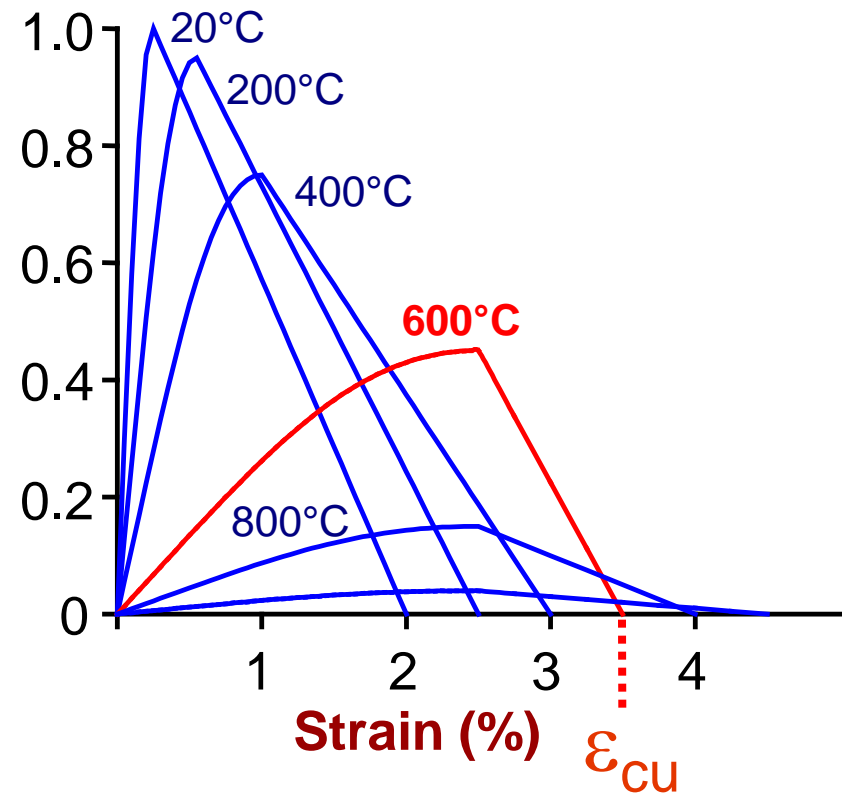

- ◆ Compressive strength at 600°C reduced by about 50%

Application of EC4 for fire resistance assessment – basic knowledge

Mechanical properties of concrete and steel at elevated temperatures

Strength
% of normal value

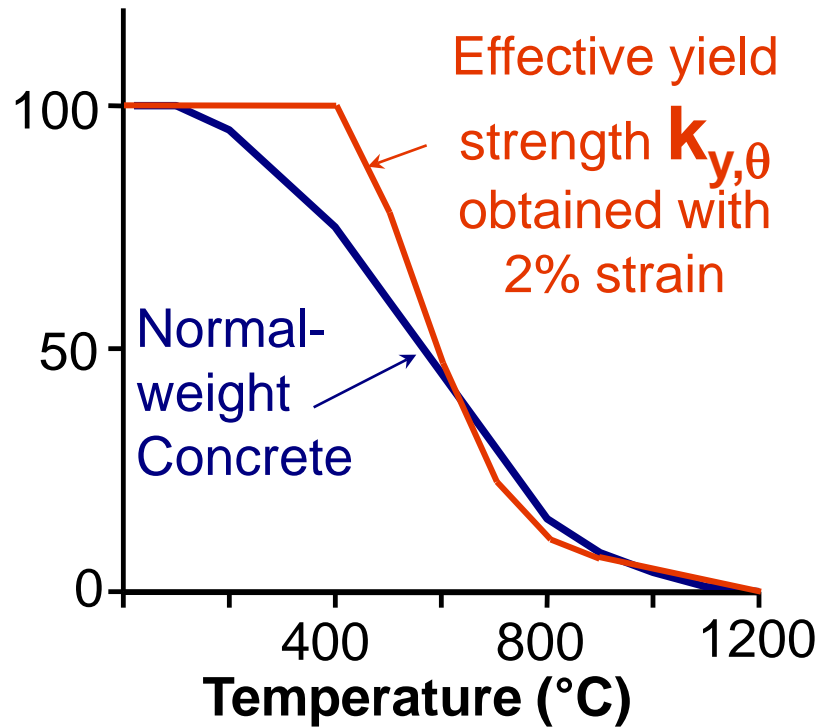

Application of EC4 for fire resistance assessment – basic knowledge

Partial safety factors of steel/composite at elevated temperatures

Material	Ambient temperature design	Fire design
Structural steel Resistance of cross section	$\gamma_{M0} = 1.00$	$\gamma_{M,fi,a} = 1.0$
Stability of members	$\gamma_{M1} = 1.00$	$\gamma_{M,fi,a} = 1.0$
Resistance of cross section In tension to fracture	$\gamma_{M2} = 1.25$	$\gamma_{M,fi,a} = 1.0$
Stud connectors	$\gamma_v = 1.25$	$\gamma_{M,fi,v} = 1.0$
Steel reinforcing bars	$\gamma_s = 1.15$	$\gamma_{M,fi,s} = 1.0$
Concrete	$\gamma_c = 1.50$	$\gamma_{M,fi,c} = 1.0$

Application of EC4 for fire resistance assessment – Tabulated Data



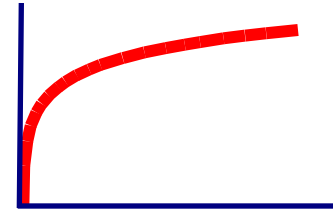

Thermal action defined under standard fire

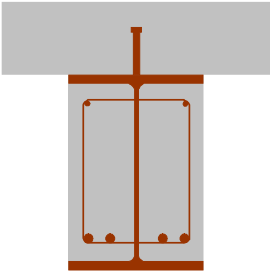

Type of analysis	Tabulated Data	Simple calculation methods		Advanced calculation models
			Critical temperature	
Member analysis	YES	YES	YES	YES
Analysis of parts of the structure	NOT applicable	Applicable in some cases	NOT applicable	YES
Global structural analysis	NOT applicable	NOT applicable	NOT applicable	YES

Application of EC4 for fire resistance assessment – Tabulated Data

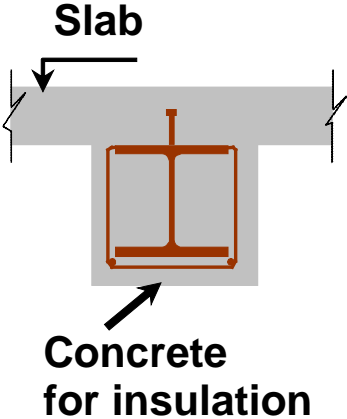
Tabulated data (steel/concrete composite members)

Composite beams	Composite columns
	
 <p>Slab</p> <p>Concrete for insulation</p>	

Design load in fire situation

$$E_{fi,d,t} = \sum_{j \geq 1} G_{k,j} + \Psi_{2,1} Q_{k,1} + \sum_{i \geq 2} \Psi_{2,i} Q_{k,i}$$

Recommended, for practical application refer to each National Annex

Load level

$$\eta_{fi,t} = \frac{E_{fi,d,t}}{R_d}$$

relative to room temperature design resistance

Application of EC4 for fire resistance assessment – Tabulated Data

Tabulated data and relevant parameters (composite partially encased columns)

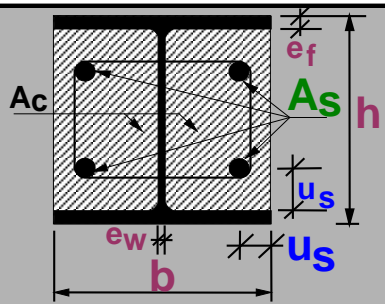

		Standard Fire Resistance			
		R30	R60	R90	R120
Minimum ratio of web to flange thickness e_w/e_f		0,5			
1	Minimum cross-sectional dimensions for load level	$\eta_{fi,t} \leq 0,28$			
1.1	minimum dimensions h and b [mm]	160	200	300	400
1.2	minimum axis distance of reinforcing bars u_s [mm]	-	50	50	70
1.3	minimum ratio of reinforcement $A_s/(A_c+A_s)$ in %	-	4	3	4
2	Minimum cross-sectional dimensions for load level	$\eta_{fi,t} \leq 0,47$			
2.1	minimum dimensions h and b [mm]	160	300	400	-
2.2	minimum axis distance of reinforcing bars u_s [mm]	-	50	70	-
2.3	minimum ratio of reinforcement $A_s/(A_c+A_s)$ in %	-	4	4	-
3	Minimum cross-sectional dimensions for load level	$\eta_{fi,t} \leq 0,66$			
3.1	minimum dimensions h and b [mm]	160	400	-	-
3.2	minimum axis distance of reinforcing bars u_s [mm]	40	70	-	-
3.3	minimum ratio of reinforcement $A_s/(A_c+A_s)$ in %	1	4	-	-

Standard fire rating

Load level $\eta_{fi,t} = E_{fi,d} / R_d$

Section dimension

Reinforcing steel

Rebars cover

Application of EC4 for fire resistance assessment – Tabulated Data

Tabulated data and relevant parameters (composite encased columns)

~~Load level $\eta_{fi,d} = E_{fi,d} / R_d$~~

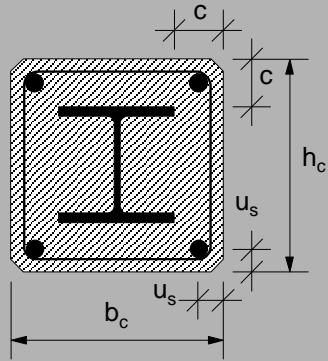

		Standard Fire Resistance						Standard fire rating
		R30	R60	R90	R120	R180	R240	
1.1	Minimum dimensions h_c and b_c [mm]	150	180	220	300	350	400	Section dimension
1.2	minimum concrete cover of steel section c [mm]	40	50	50	75	75	75	
1.3	minimum axis distance of reinforcing bars u_s [mm]	20*	30	30	40	50	50	
or								
2.1	Minimum dimensions h_c and b_c [mm]	-	200	250	350	400	400	Section and rebar Cover
2.2	minimum concrete cover of steel section c [mm]	-	40	40	50	60	60	
2.3	minimum axis distance of reinforcing bars u_s [mm]	-	20*	20*	30	40	40	

NOTE : *) These values have to be checked according to 4.4.1.2 of EN 1992-1-1

Establishing fire resistance of composite structures using simple process

❑ Thermal action defined under standard fire

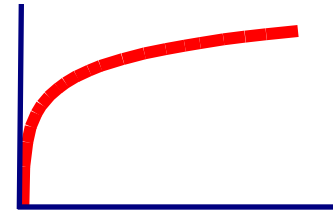

Type of analysis	Tabulated Data	Simple calculation methods		Advanced calculation models
			Critical temperature	
Member analysis	YES	YES	YES	YES
Analysis of parts of the structure	NOT applicable	Applicable in some cases	NOT applicable	YES
Global structural analysis	NOT applicable	NOT applicable	NOT applicable	YES

Establishing fire resistance of composite structures using simple process

Simple calculation models and critical temperature for composite members

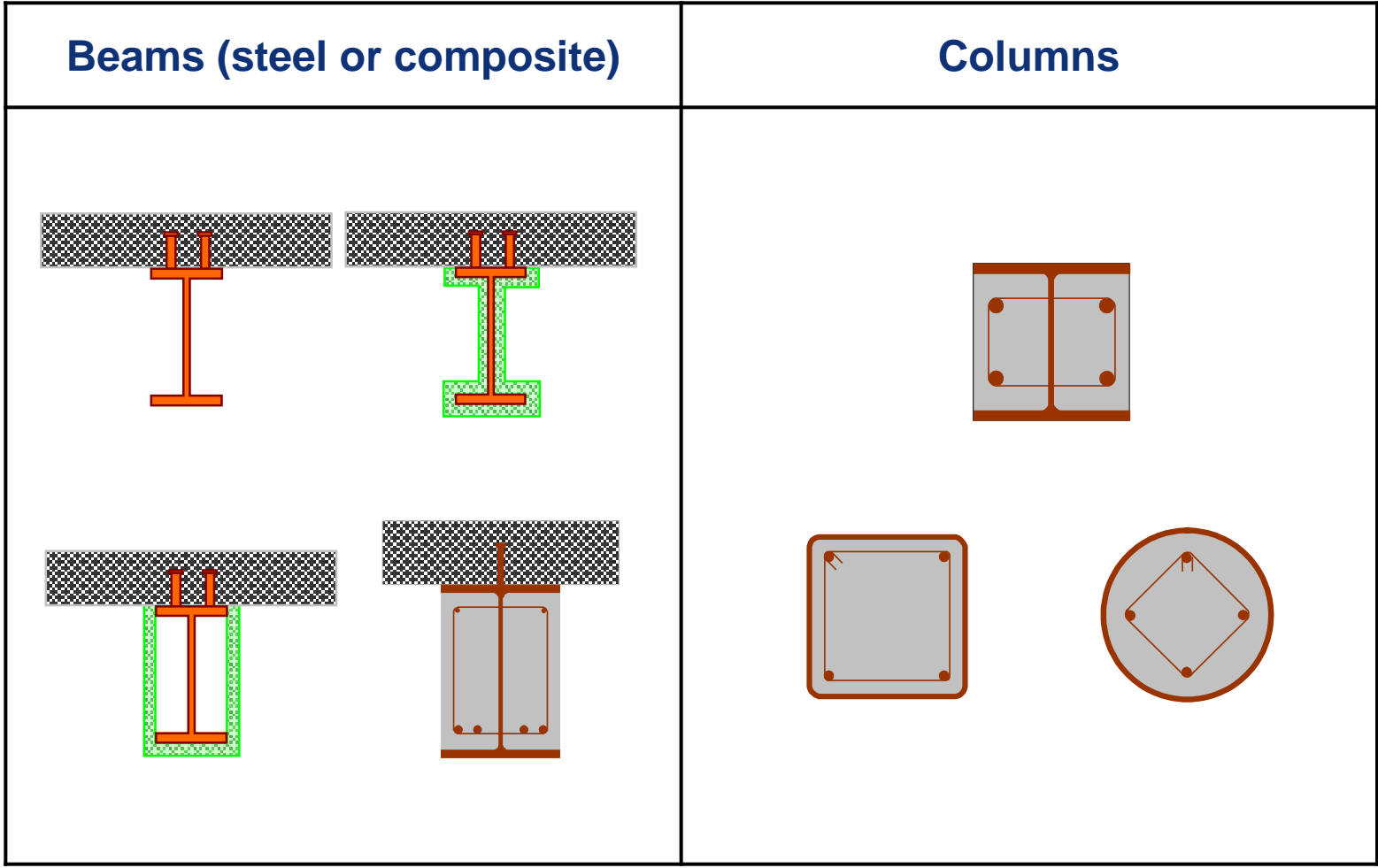

Establishing fire resistance of composite structures using simple process



Critical temperature method for composite beams

Simply determined composite beam

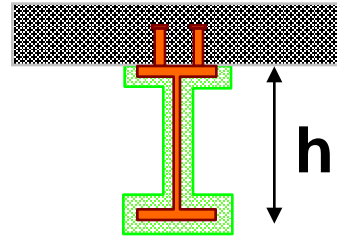
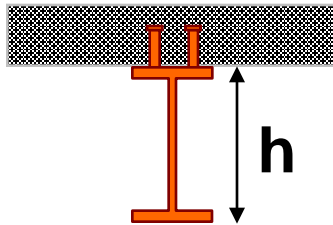

$h_c > 120\text{mm}$

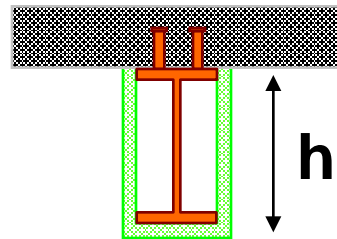

$h < 500\text{mm}$

Establishing fire resistance of composite structures using simple process

FIRE RESISTANCE

Action in fire situation $E_{fi,d,t}$

~~Classify member~~

~~Resistance at 20°C by fire rules~~
 $R_{d,t}$

Load level for fire design $\eta_{d,t}$

$$\eta_{fi,t} = k_{y,\theta_{cr}}$$

Critical temperature
 θ_{cr}

Composite Steel/Concrete Temperature (UNPROTECTED Steel)

Find Section Factor
 A_m/V and k_{sh}

Building regulations
 $t_{fi,requ}$

$\theta_{t,fi,requ}$

Is
 $\theta_{cr} \geq \theta_{t,fi,requ}$
??

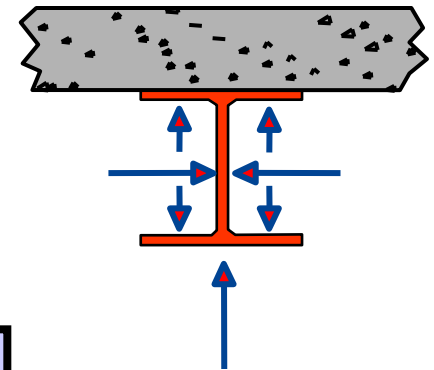

Establishing fire resistance of composite structures using simple process

FIRE RESISTANCE

Action in fire situation $E_{fi,d,t}$

~~Classify member~~

~~Resistance at 20°C by fire rules~~
 ~~$R_{fi,d,t}$~~

Load level for fire design $\eta_{fi,t}$

$$\eta_{fi,t} = k_{y,\theta_{cr}}$$

Critical temperature
 θ_{cr}

Steel Temperature (PROTECTED)

Find Section Factor
 A_m/V and k_{sh}

Building regulations
 $t_{fi,requ}$

$$\theta_{t,fi,requ}$$

Is

$$\theta_{cr} \geq \theta_{t,fi,requ}$$

??

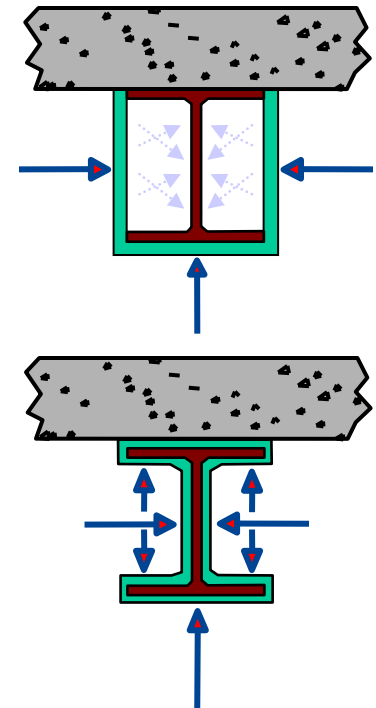

Critical temperature of steel members

- Steel member temperature (assumed to be uniform and equal to bottom flange temperature)

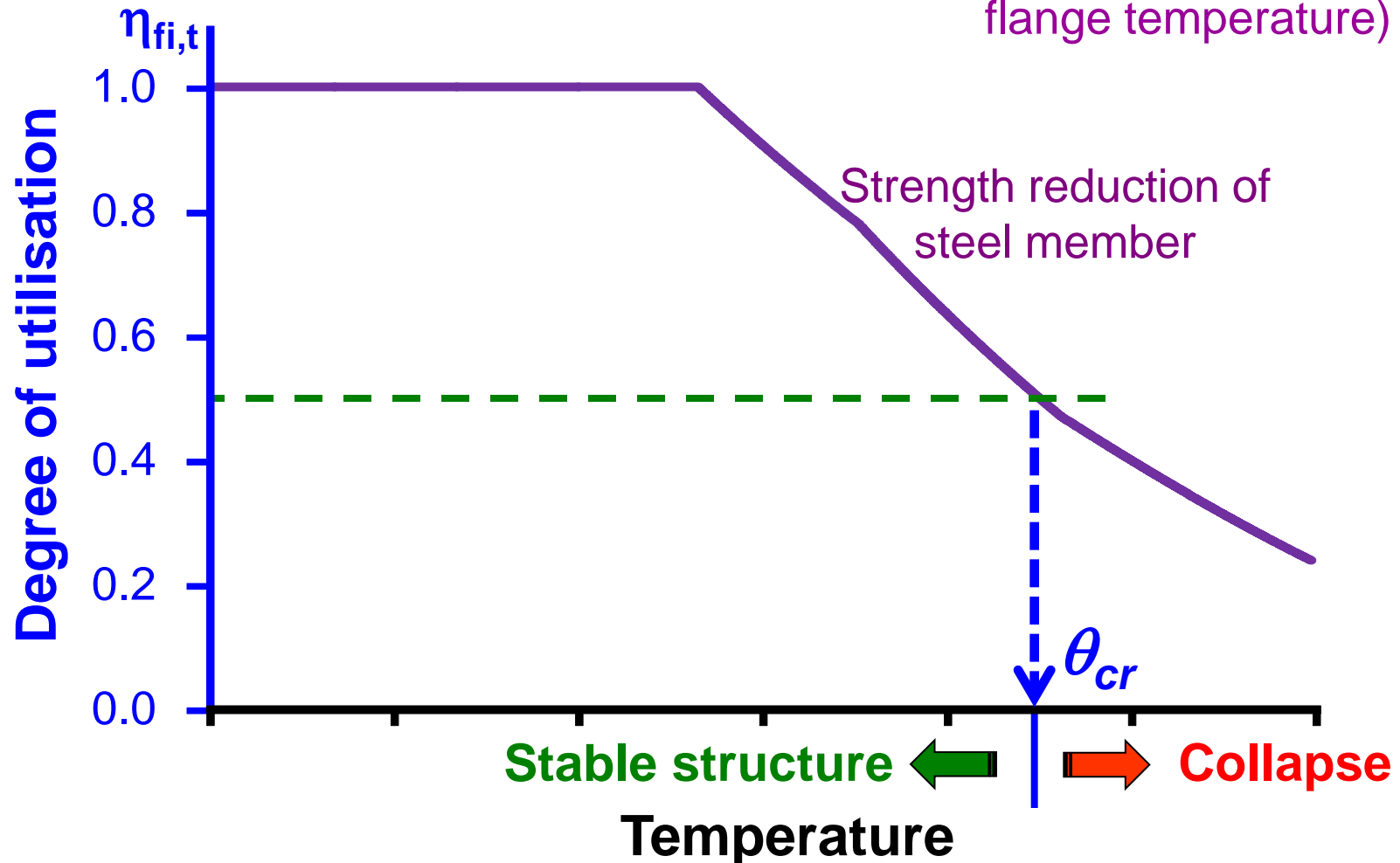

Simple Calculation Models

Steel elements (sections, Steel Sheet, Rebars)

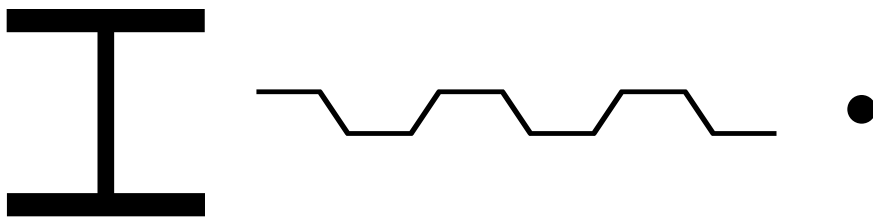

Concrete

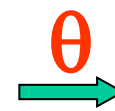
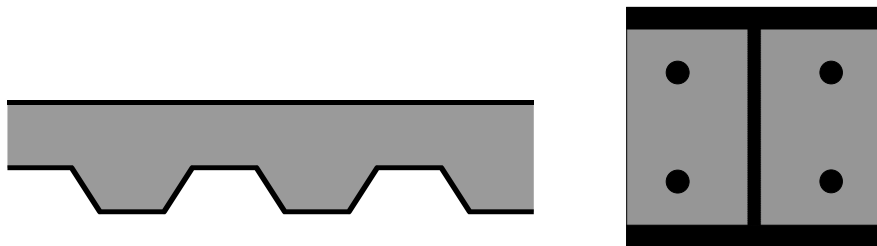

$$k_{y,\theta}$$

$$k_{s,\theta}$$



$$f_{y,\theta}$$

$$f_{s,\theta}$$

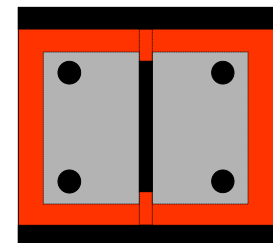
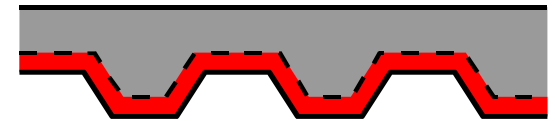
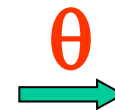

Composite slab fire design

- ⇒ No tabulated data
- ⇒ Simplified calculation (§4.3)
 - Only for use with ISO fire
 - Integrity criteria E is assumed always satisfied
 - Thermal insulation I

Criteria:

- ✓ $\Delta T_{\max} \leq 180$ |
- ✓ $\Delta T_{\text{average}} \leq 14$

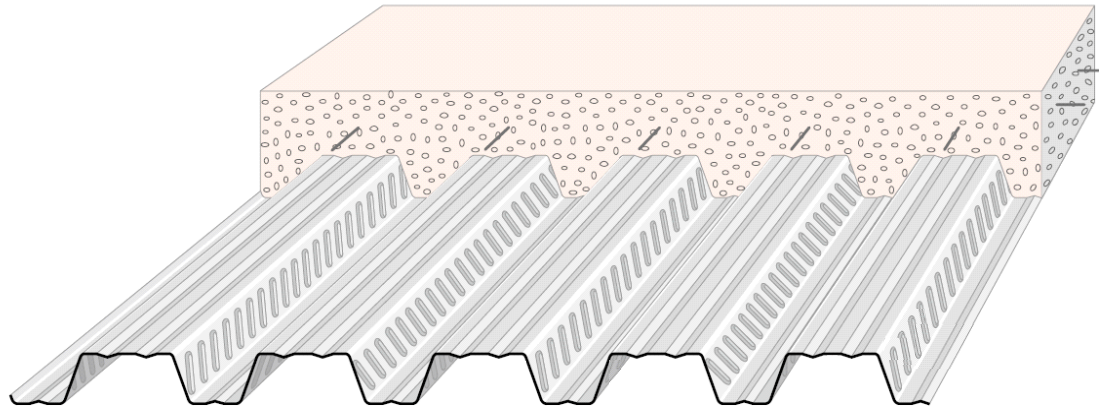

The fire resistance t_i [min] corresponding to criteria I is given by

$$t_i = a_0 + a_1 \cdot h_1 + a_2 \cdot \Phi + a_3 \cdot \frac{A}{L_r} + a_4 \cdot \frac{1}{l_3} + a_5 \cdot \frac{A}{L_r} \cdot \frac{1}{l_3}$$

with

$$\frac{A}{L_r} = \frac{h_2 \cdot \left(\frac{l_1 + l_2}{2} \right)}{l_2 + 2 \sqrt{h_2^2 + \left(\frac{l_1 - l_2}{2} \right)^2}}$$

$$\Phi = \left(\sqrt{h_2^2 + \left(l_3 + \frac{l_1 - l_2}{2} \right)^2} - \sqrt{h_2^2 + \left(\frac{l_1 - l_2}{2} \right)^2} \right) / l_3$$

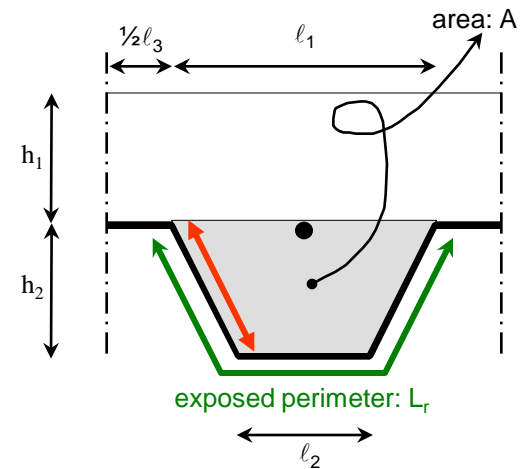

Table D.1: Coefficients for determination of the fire resistance with respect to thermal insulation

	a_0 [min]	a_1 [min/mm]	a_2 [min]	a_3 [min/mm]	a_4 [mm min]	a_5 [min]
Normal weight concrete	-28,8	1,55	-12,6	0,33	-735	48,0
Lightweight concrete	-79,2	2,18	-2,44	0,56	-542	52,3

Simple Calculation Models

$$\Phi = \left(\sqrt{h_2^2 + \left(l_3 + \frac{l_1 - l_2}{2} \right)^2} - \sqrt{h_2^2 + \left(\frac{l_1 - l_2}{2} \right)^2} \right) / l_3$$

Φ is the view factor $F_{A,B}$ calculated by the rule of Hottel

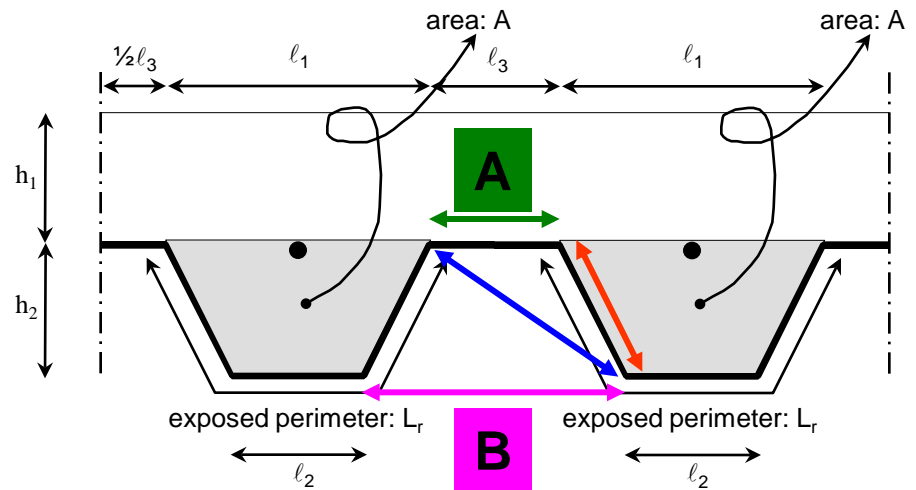

Alternative method : minimum effective thickness

(1) The effective h_{eff} is given by the formula :

$$h_{eff} = h_1 + 0,5 \cdot h_2 \left(\frac{l_1 + l_2}{l_1 + l_3} \right) \quad \text{for } h_2 / h_1 \leq 1,5 \text{ and } h_1 > 40\text{mm}$$

$$h_{eff} = h_1 \left[1 + 0,75 \cdot \left(\frac{l_1 + l_2}{l_1 + l_3} \right) \right] \quad \text{for } h_2 / h_1 > 1,5 \text{ and } h_1 > 40\text{mm}$$

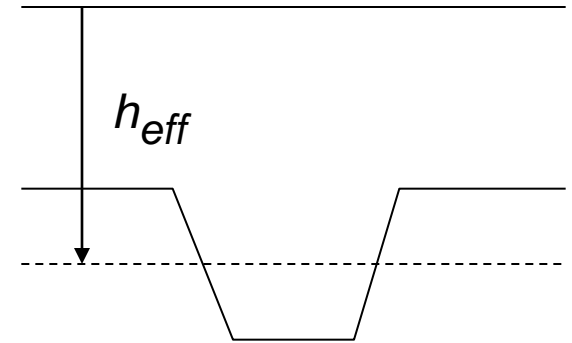
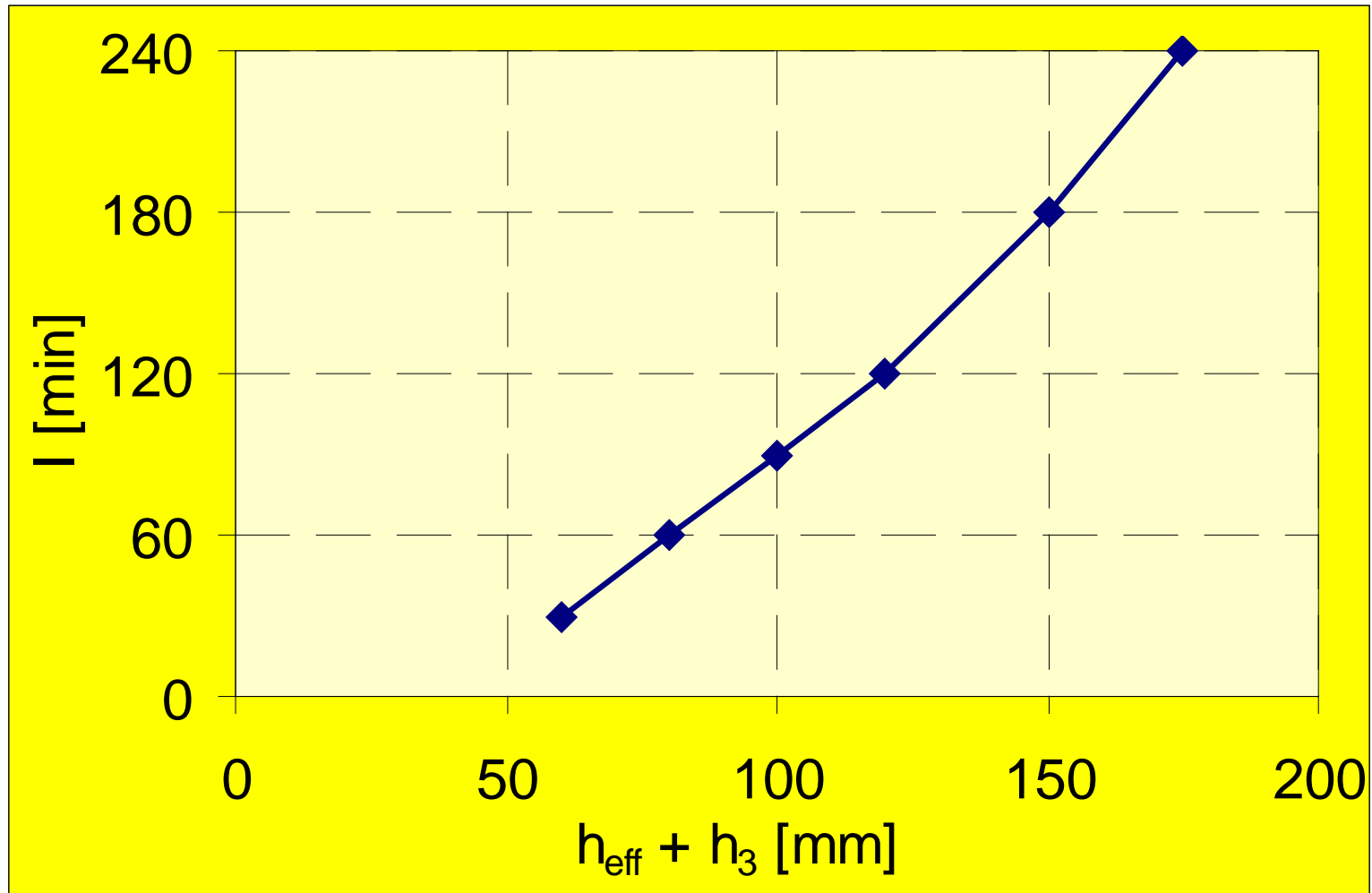

Table D.6: Minimum effective thickness as a function of the standard fire resistance.

Standard Fire Resistance	Minimum effective thickness h_{eff} [mm]
I 30	60 - h_3
I 60	80 - h_3
I 90	100 - h_3
I 120	120 - h_3
I 180	150 - h_3
I 240	175 - h_3

Simple Calculation Models



Composite slab fire design

- ⇒ No tabulated data
- ⇒ Simplified calculation (§4.3)
 - Only for use with ISO fire
 - Integrity criteria E is assumed always satisfied
 - Thermal insulation I
 - Load bearing capacity R
 - If the design conforms to EN 1994-1-1, $R \geq 30$ minutes.
 - For composite slabs, the bending capacity has to be determined by a plastic design.

Composite slab fire design

Temperature field

The temperature θ_a of the **lower flange**, **web** and **upper flange** of the steel decking may be given by:

$$\theta_a = b_0 + b_1 \cdot \frac{1}{l_3} + b_2 \cdot \frac{A}{L_r} + b_3 \cdot \Phi + a_4 \cdot \Phi^2 \quad (D.2.1)$$

Concrete	Fire resistance [min]	Part of the steel sheet	b_0 [°C]	b_1 [°C]. mm	b_2 [°C]. mm	b_3 [°C]	b_4 [°C]
Normal weight concrete	60	Lower flange	951	-1197	-2,32	86,4	-150,7
		Web	661	-833	-2,96	537,7	-351,9
		Upper flange	340	-3269	-2,62	1148,4	-679,8
	90	Lower flange	1018	-839	-1,55	65,1	-108,1
		Web	816	-959	-2,21	464,9	-340,2
		Upper flange	618	-2786	-1,79	767,9	-472,0
	120	Lower flange	1063	-679	-1,13	46,7	-82,8
		Web	925	-949	-1,82	344,2	-267,4
		Upper flange	770	-2460	-1,67	592,6	-379,0

Composite slab fire design

Temperature field

The temperature θ_s of the reinforcement bars in **the rib**, if any according to figure D.2.1, as follows:

$$\theta_s = c_0 + c_1 \cdot \frac{u_3}{h_2} + c_2 \cdot z + c_3 \cdot \frac{A}{L_r} + c_4 \cdot \alpha + c_5 \cdot \frac{1}{l_3} \quad (D.2.2)$$

$$\frac{1}{z} = \frac{1}{\sqrt{u_1}} + \frac{1}{\sqrt{u_2}} + \frac{1}{\sqrt{u_3}}$$

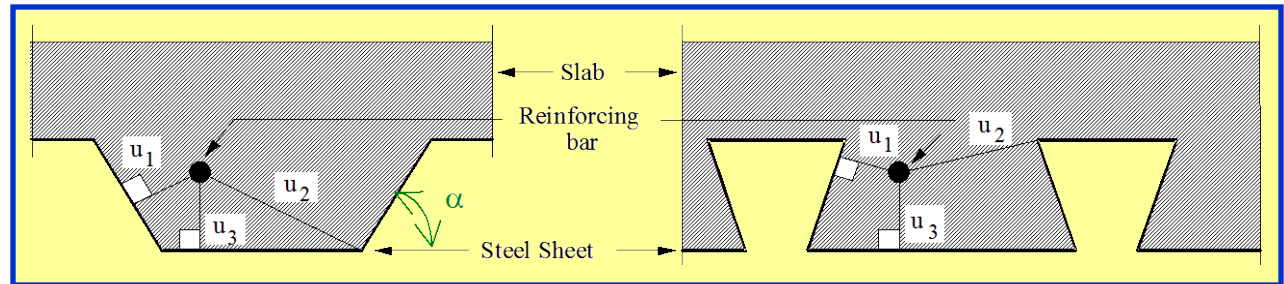
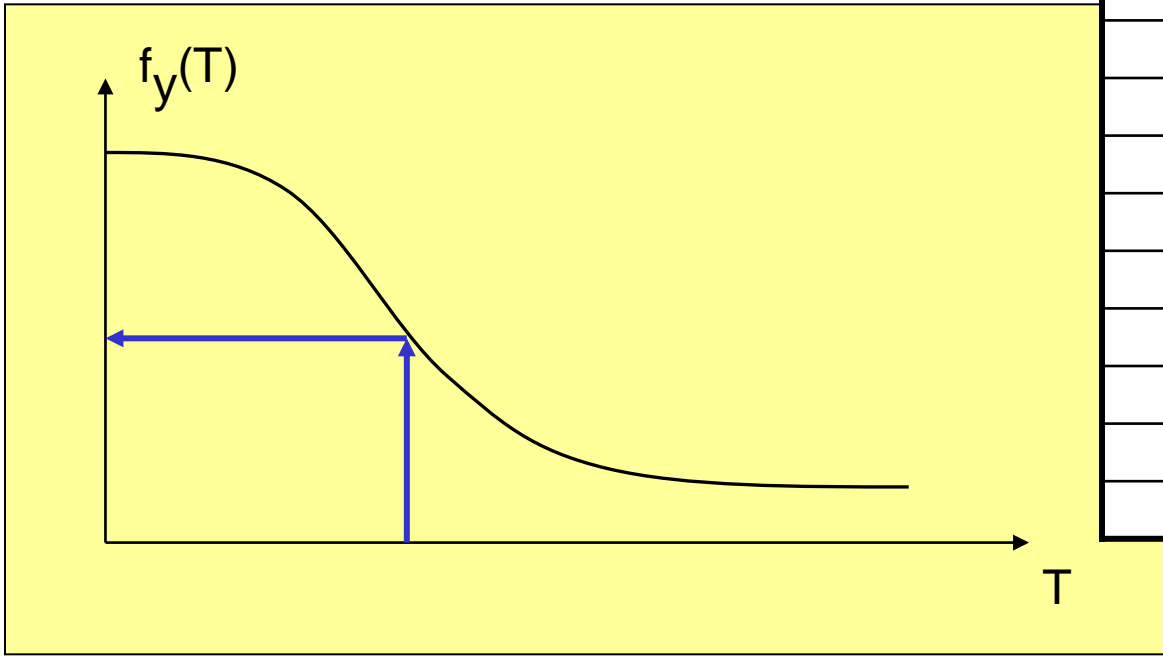
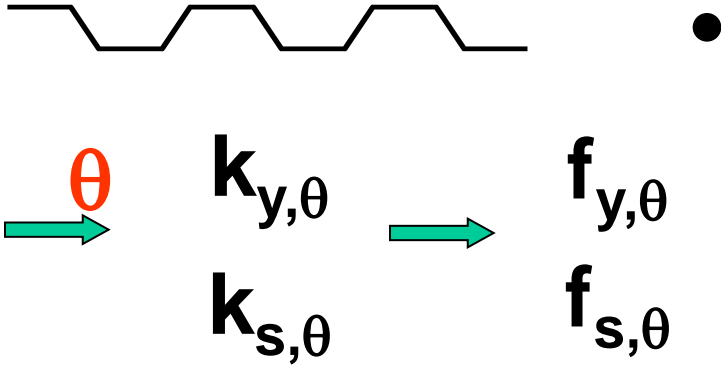

Table D.2.2 : Coefficients for the determination of the temperatures of the reinforcement bars in the rib.

Concrete	Fire resistance [min]	c_0 [°C]	c_1 [°C]	c_2 [°C]. mm ^{0.5}	c_3 [°C].mm	c_4 [°C/°]	c_5 [°C].mm
Normal weight concrete	60	1191	-250	-240	-5,01	1,04	-925
	90	1342	-256	-235	-5,30	1,39	-1267
	120	1387	-238	-227	-4,79	1,68	-1326

Composite slab fire design



	Steel	Reinforcing steel	Concrete
Temperature [°C]	$f_y(T)/f_y$	$f_{sy}(T)/f_{sy}$	$f_c(T)/f_c$
20	1.00	1.00	1.00
100	1.00	1.00	1.00
200	1.00	1.00	0.95
300	1.00	1.00	0.85
400	1.00	0.94	0.75
500	0.78	0.67	0.60
600	0.47	0.40	0.45
700	0.23	0.12	0.30
800	0.11	0.11	0.15
900	0.06	0.08	0.08
1000	0.04	0.05	0.04
1100	0.02	0.03	0.01
1200	0.00	0.00	0.00

Bending capacity in sagging moment $M_{fi,Rd}^+$

The plastic neutral axis of a composite slab or composite beam may be determined from :

$$\sum_{i=1}^n A_i k_{y,\theta,i} \left(\frac{f_{y,i}}{\gamma_{M,fi,a}} \right) + \alpha_{slab} \sum_{j=1}^m A_j k_{c,\theta,j} \left(\frac{f_{c,j}}{\gamma_{M,fi,c}} \right) = 0 \quad \alpha_{slab} = 0,85$$

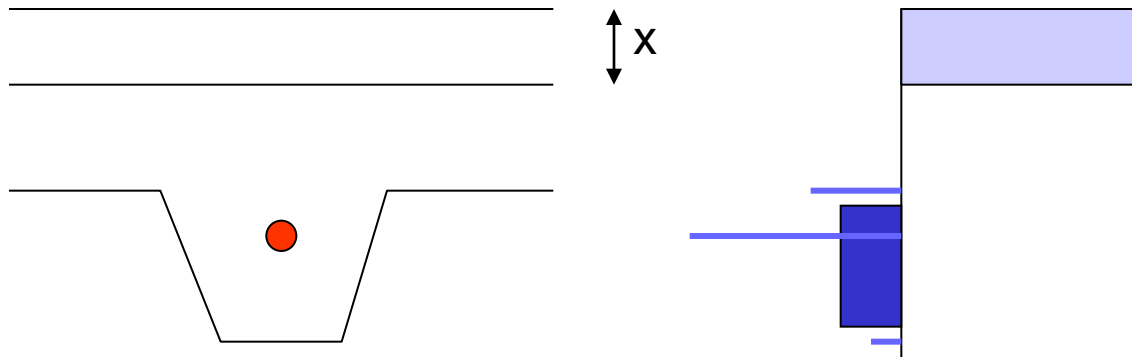

Design moment resistance

The design moment resistance $M_{fi,t,Rd}$ may be determined from :

$$M_{fi,t,Rd} = \sum_{i=1}^n A_i z_i k_{y,\theta,i} \left(\frac{f_{y,i}}{\gamma_{M,fi}} \right) + \alpha_{slab} \sum_{j=1}^m A_j z_j k_{c,\theta,j} \left(\frac{f_{c,j}}{\gamma_{M,fi,c}} \right)$$

Bending capacity in hogging moment $M_{fi,Rd}^-$

Temperature field

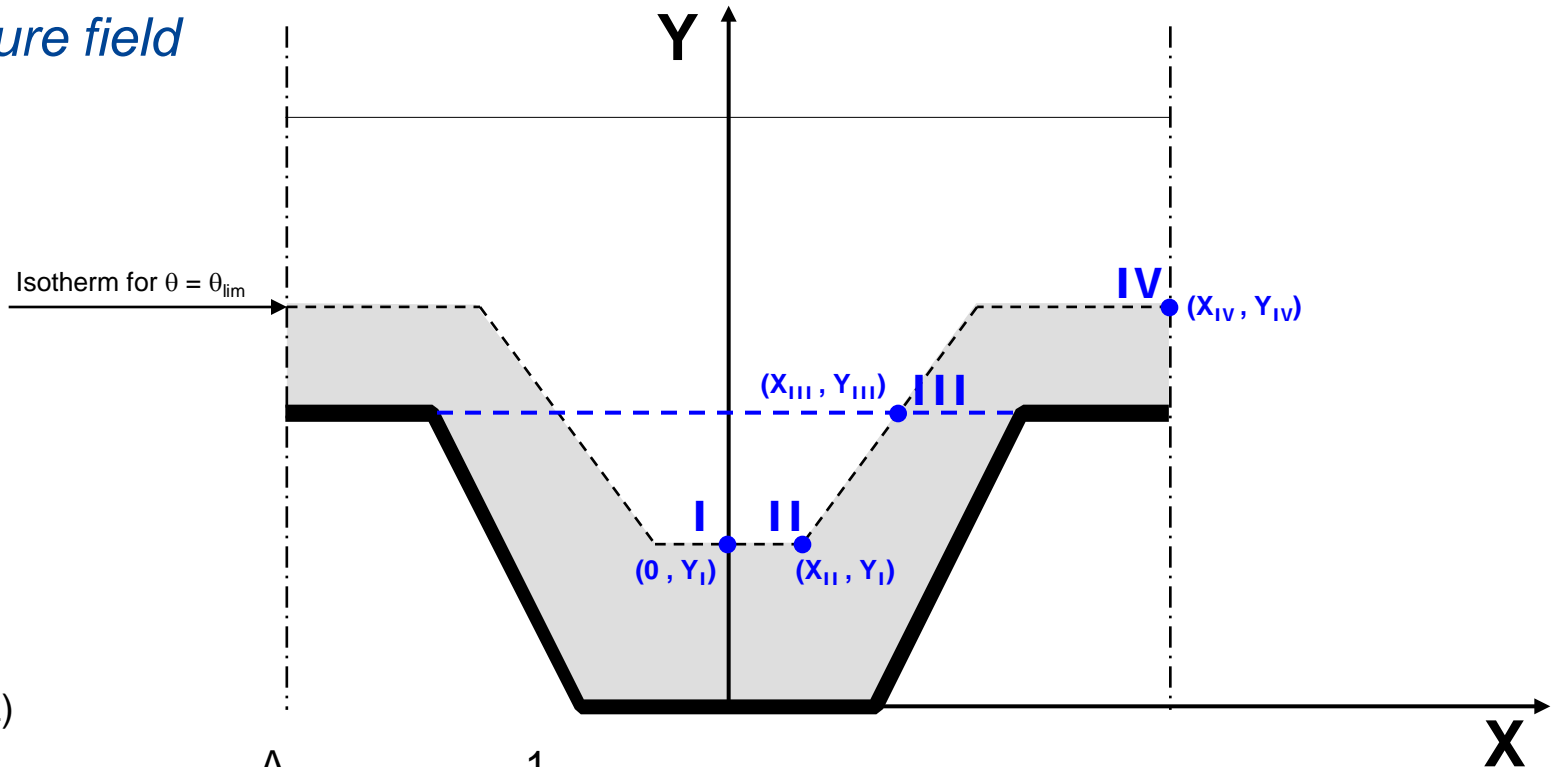

X_i and $Y_i = f(z)$

$$\text{with } \theta_{lim} = d_0 + d_1 \cdot N_s + d_2 \cdot \frac{A}{L_r} + d_3 \cdot \Phi + d_4 \cdot \frac{1}{l_3}$$

and z is obtained from the equation for the determination of θ_s , assuming that $u_3/h_2 = 0,75$ and $\theta_s = \theta_{lim}$

$$\theta_s = c_0 + c_1 \cdot \frac{u_3}{h_2} + c_2 \cdot z + c_3 \cdot \frac{A}{L_r} + c_4 \cdot \alpha + c_5 \cdot \frac{1}{l_3}$$

Bending capacity in hogging moment $M_{fi,Rd}^-$

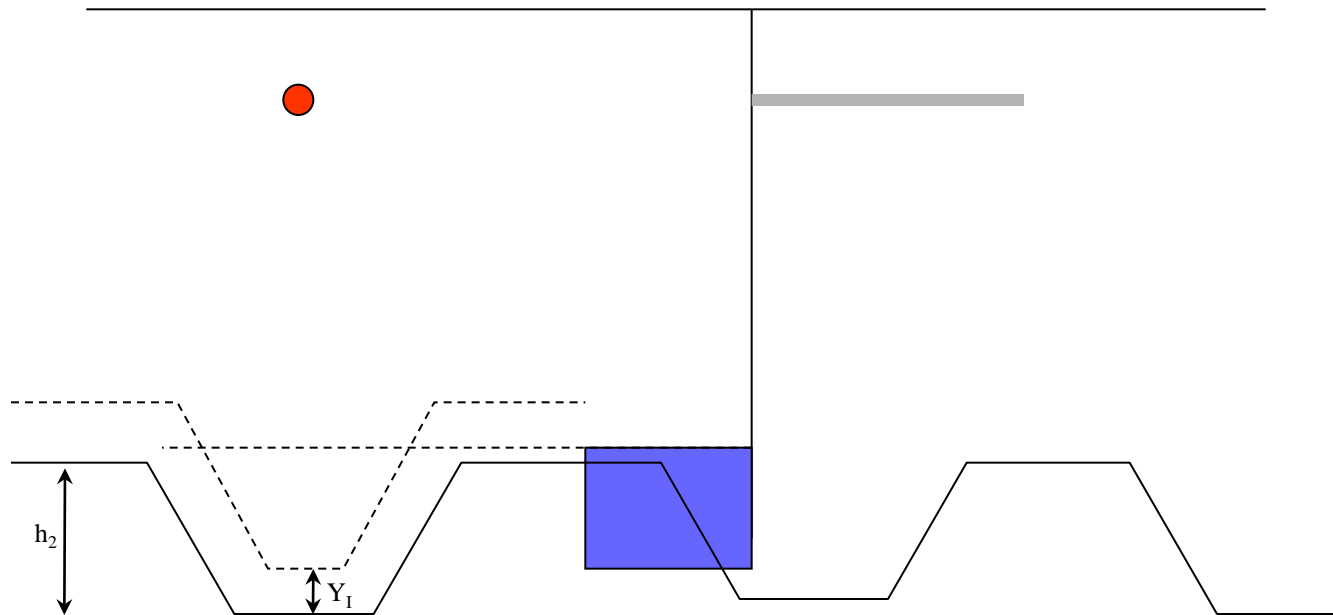

If $Y_1 > h_2$  Alternative procedure based on the effective thickness

Bending capacity in hogging moment $M_{fi,Rd}^-$

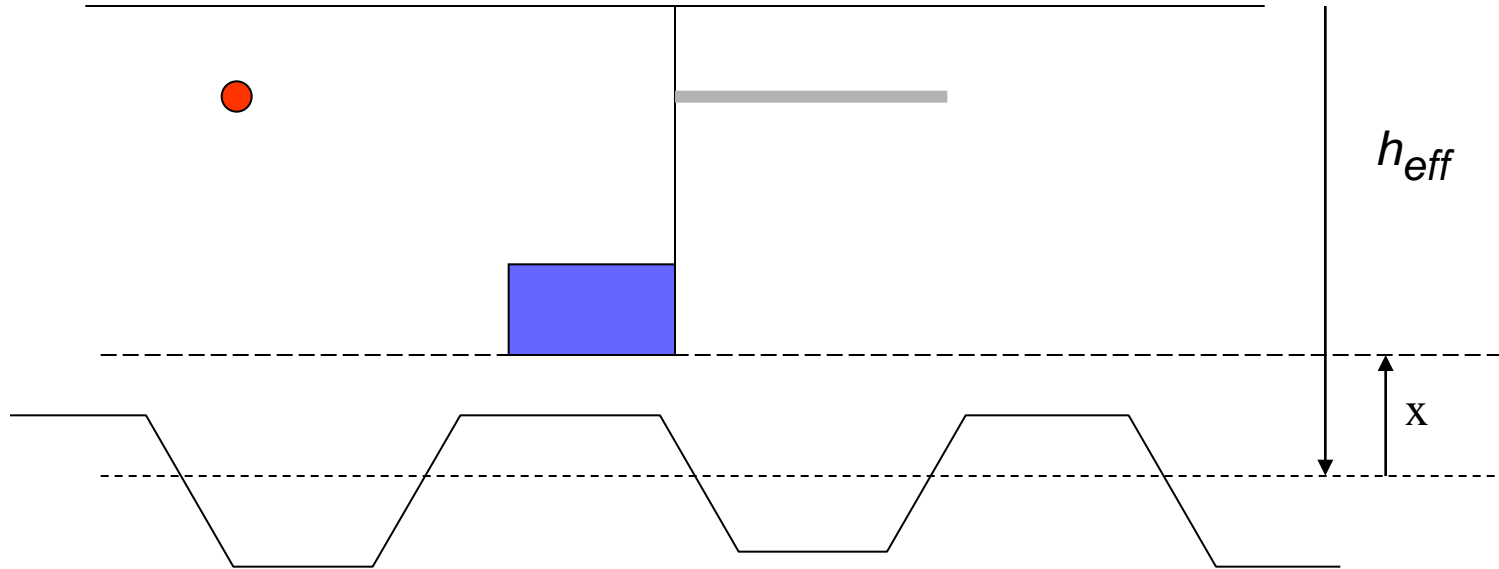

Depth x [mm]	Temperature θ_c [°C] after a fire duration in min. of					
	30'	60'	90'	120'	180'	240'
5	535	705				
10	470	642	738			
15	415	581	681	754		
20	350	525	627	697		
25	300	469	571	642	738	
30	250	421	519	591	689	740
35	210	374	473	542	635	700
40	180	327	428	493	590	670
45	160	289	387	454	549	645
50	140	250	345	415	508	550
55	125	200	294	369	469	520
60	110	175	271	342	430	495
80	80	140	220	270	330	395
100	60	100	160	210	260	305

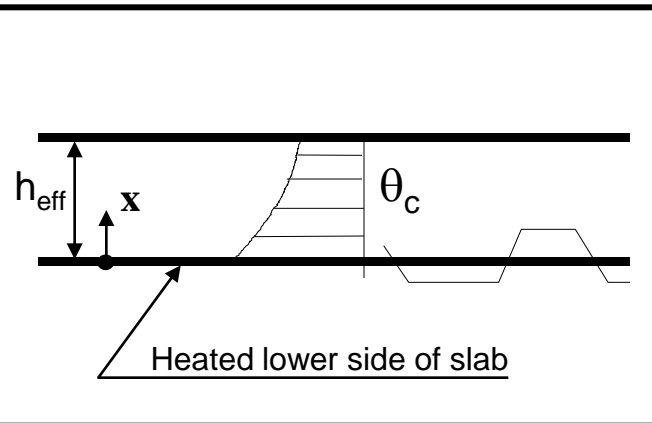

Bending capacity of the composite slab

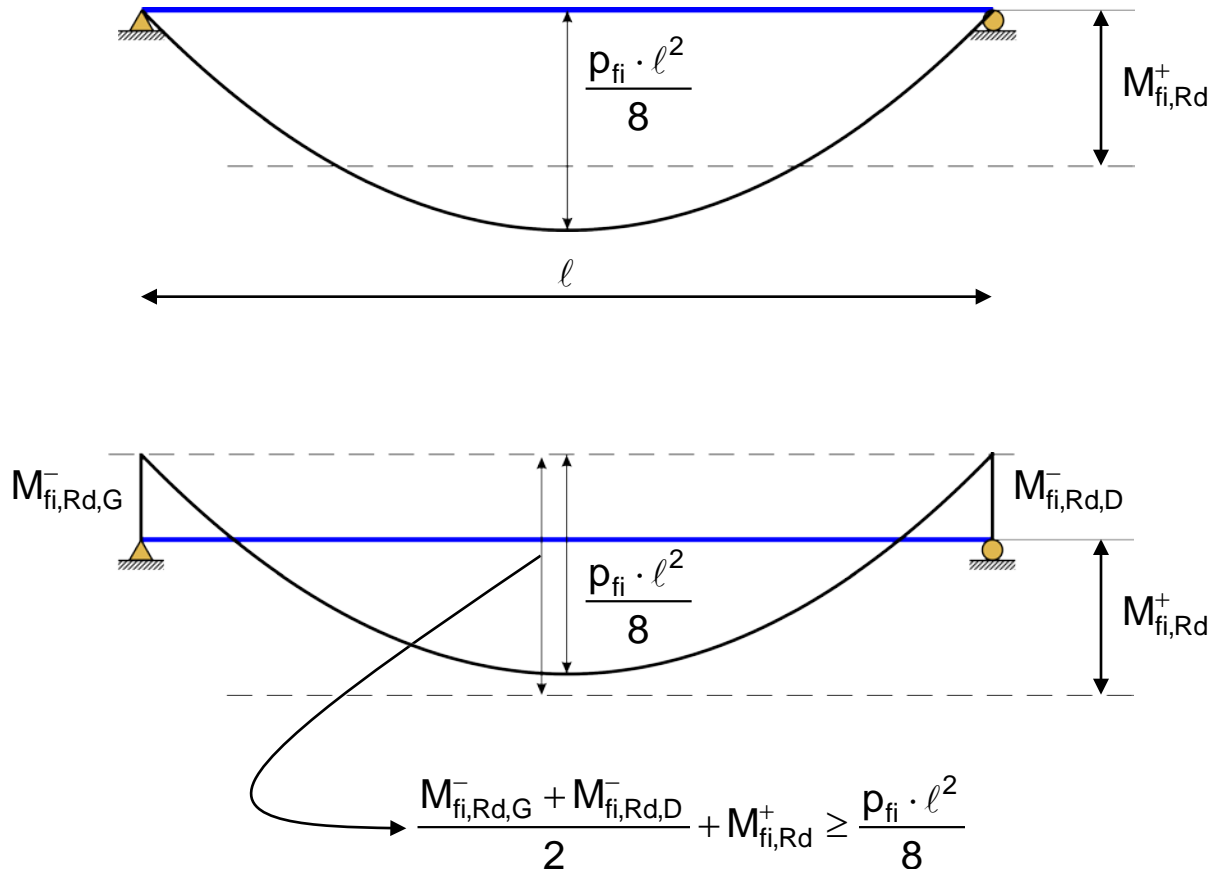

Bending capacity of the composite slab

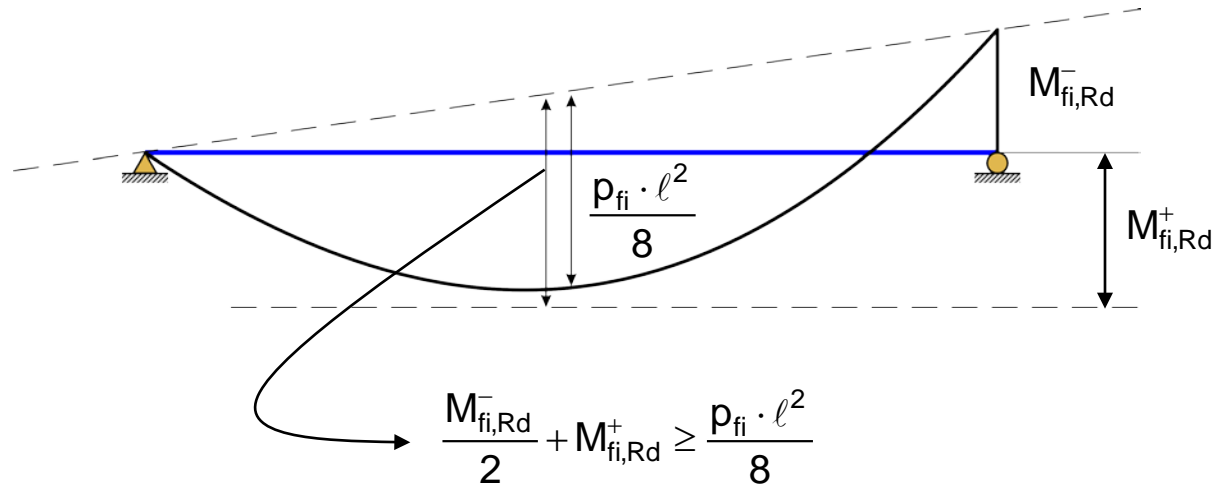

$$\frac{p_{fi} \cdot l^2}{8} = \frac{M_{fi,Rd}^+}{2} + \frac{M_{fi,Rd}^-}{4} + \left[\left(M_{fi,Rd}^- + 2 \cdot M_{fi,Rd}^+ \right)^2 - \left(M_{fi,Rd}^- \right)^2 \right]^{0.5} / 4$$

Composite beam fire design

Temperature field

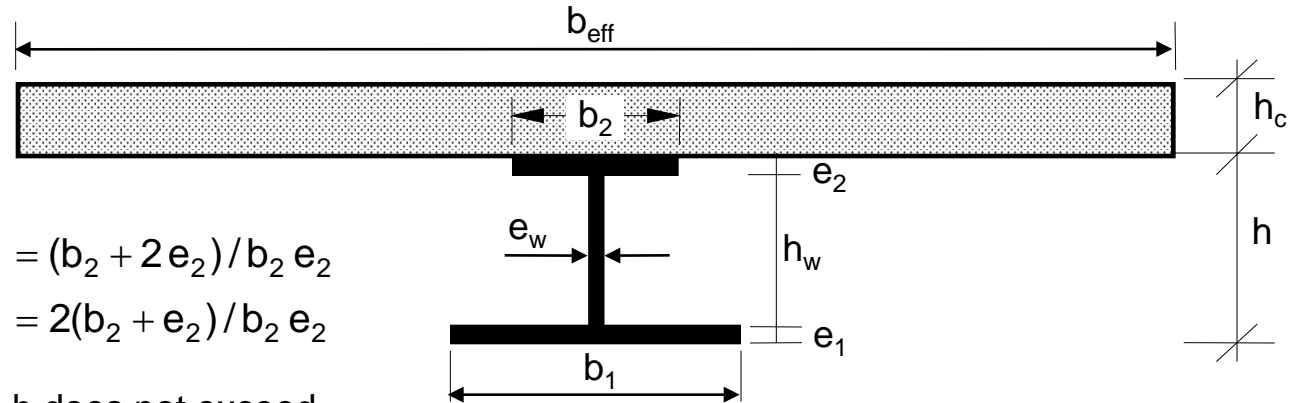

Upper flange A_i / V_i or $A_{p,i} / V_i = (b_2 + 2e_2) / b_2 e_2$
 A_i / V_i or $A_{p,i} / V_i = 2(b_2 + e_2) / b_2 e_2$

Web

If the beam depth h does not exceed 500mm, the temperature of the web may be taken as equal to that of the lower flange.

$$\Delta\theta_{a,t} = k_{\text{shadow}} \left(\frac{1}{c_a \rho_a} \right) \left(\frac{A_i}{V_i} \right) \cdot h_{\text{net}} \cdot \Delta t$$

Lower flange A_i / V_i or $A_{p,i} / V_i = 2(b_1 + e_1) / b_1 e_1$

Depth X [mm]	Temperature θ_e [°C] after a fire duration in min. of					
	30'	60'	90'	120'	180'	240'
5	535	705				
10	470	642	738			
15	415	581	681	754		
20	350	525	627	697		
25	300	469	571	642	738	
30	250	421	519	591	689	740
35	210	374	473	542	635	700
40	180	327	428	493	590	670
45	160	289	387	454	549	645
50	140	250	345	415	508	550
55	125	200	294	369	469	520
60	110	175	271	342	430	495
80	80	140	220	270	330	395
100	60	100	160	210	260	305

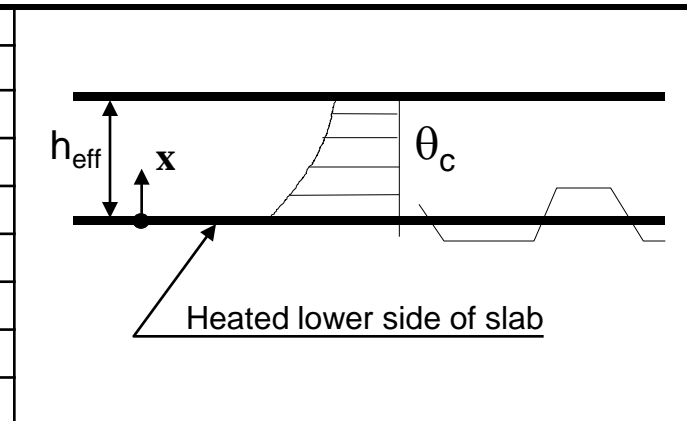

Composite beam fire design

Structural behaviour - Bending moment resistance model M_{Rd}^+

Classical determination of the bending moment resistance, taking into account the variation of material properties with temperatures, see Annex E.

⇒ No strength reduction in concrete if $T < 250^\circ\text{C}$

⇒ The value of the tensile force is limited by the resistance of the shear connectors : $T^+ \leq N \cdot P_{fi,Rd}$

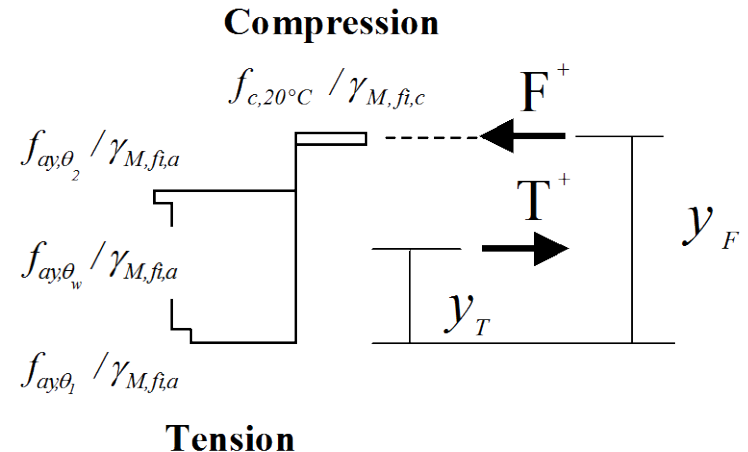
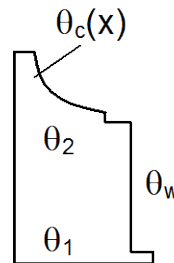
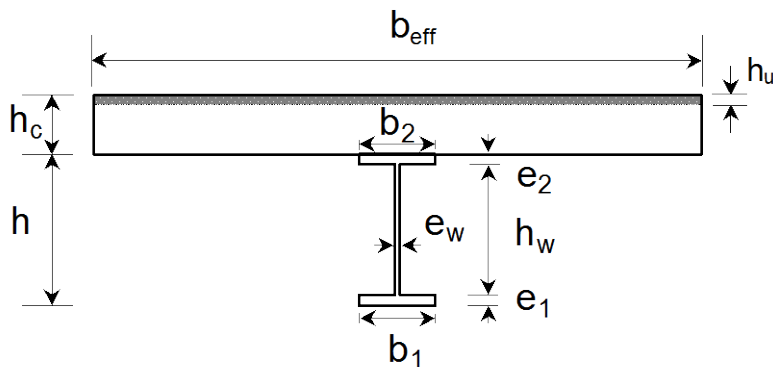

Composite beam fire design

Structural behaviour - Bending moment resistance model M_{Rd}^+

Verification of the stud connectors

$P_{fi,Rd}$ = minimum of the 2 following values:

$$\left\{ \begin{array}{l} P_{fi,Rd} = 0,8 \cdot k_{u,\theta} \cdot P_{Rd} \quad \text{with } P_{Rd} \text{ obtained from equation 6.18 of EN1994-1-1} \\ P_{fi,Rd} = k_{c,\theta} \cdot P_{Rd} \quad \quad \quad \text{with } P_{Rd} \text{ obtained from equation 6.19 of EN1994-1-1} \end{array} \right.$$

with

⇒ $\gamma_{m,fi}$ used instead of γ_v

⇒ $k_{u,\theta}$ and $k_{c,\theta}$ defining the decrease of material strength

⇒ θ_u in the stud = $0.80 \theta_{upper\ flange}$

⇒ θ_c of the concrete = $0.40 \theta_{upper\ flange}$

Composite beam fire design

Hogging moment resistance at an intermediate support

Choose the effective width of the slab to have the slab completely cracked, but $b_{\text{eff}}(T) \leq b_{\text{eff}}(20^\circ\text{C})$.

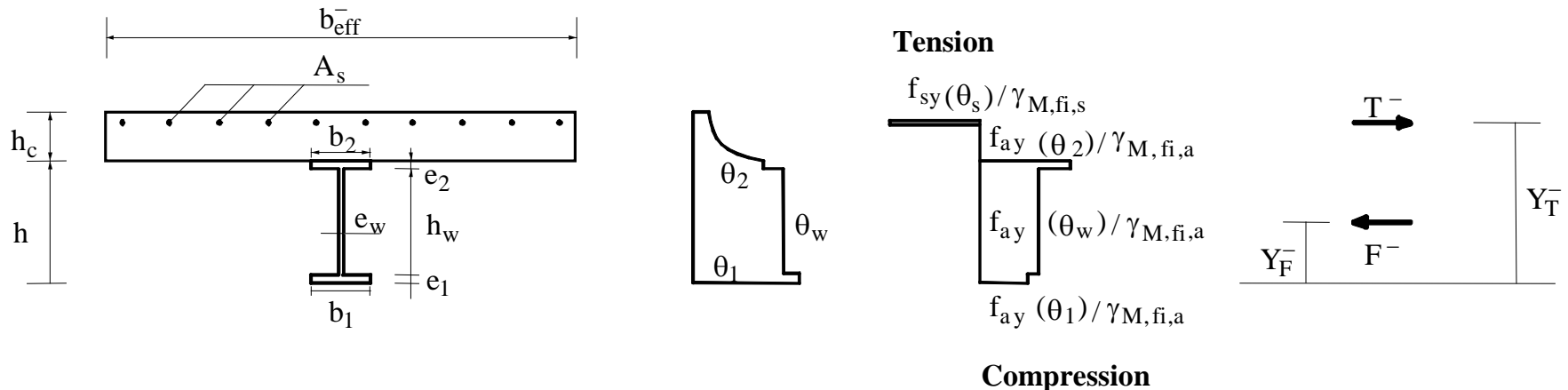

If web or lower flange are Class 3, reduce its width according to EN 1993-1-5.
If web or lower flange are Class 4, its resistance may be neglected.

Note: classification according to EN1993-1-2 $\varepsilon = 0,85 \left[235 / f_y \right]^{0,5}$

Simple calculation model for composite members

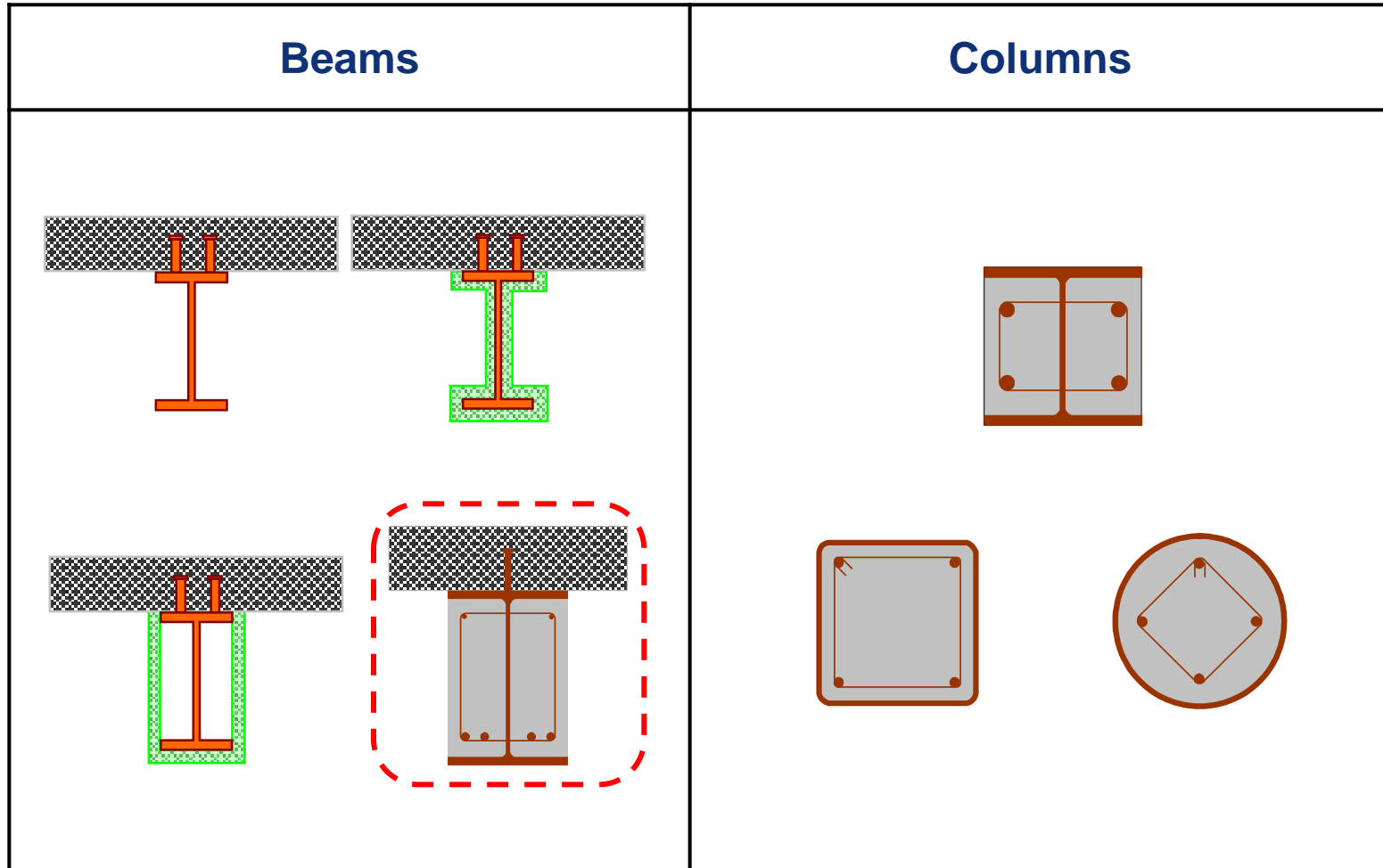

Simple calculation model for composite members

Partially Encased Beam

Sagging moment $M_{fi,Rd}^+$

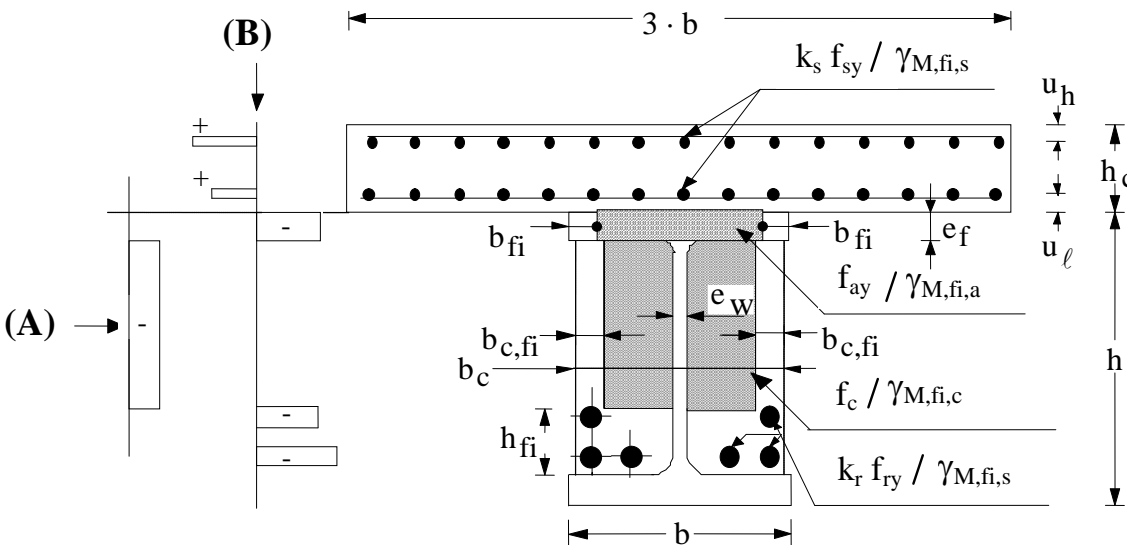
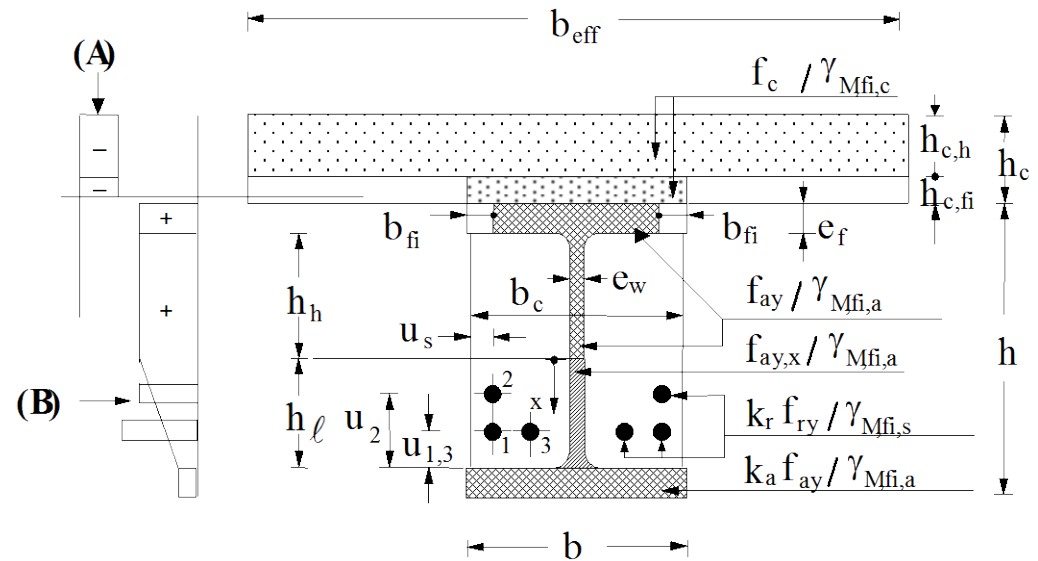

Hogging moment $M_{fi,Rd}^-$

Simple calculation model for composite members

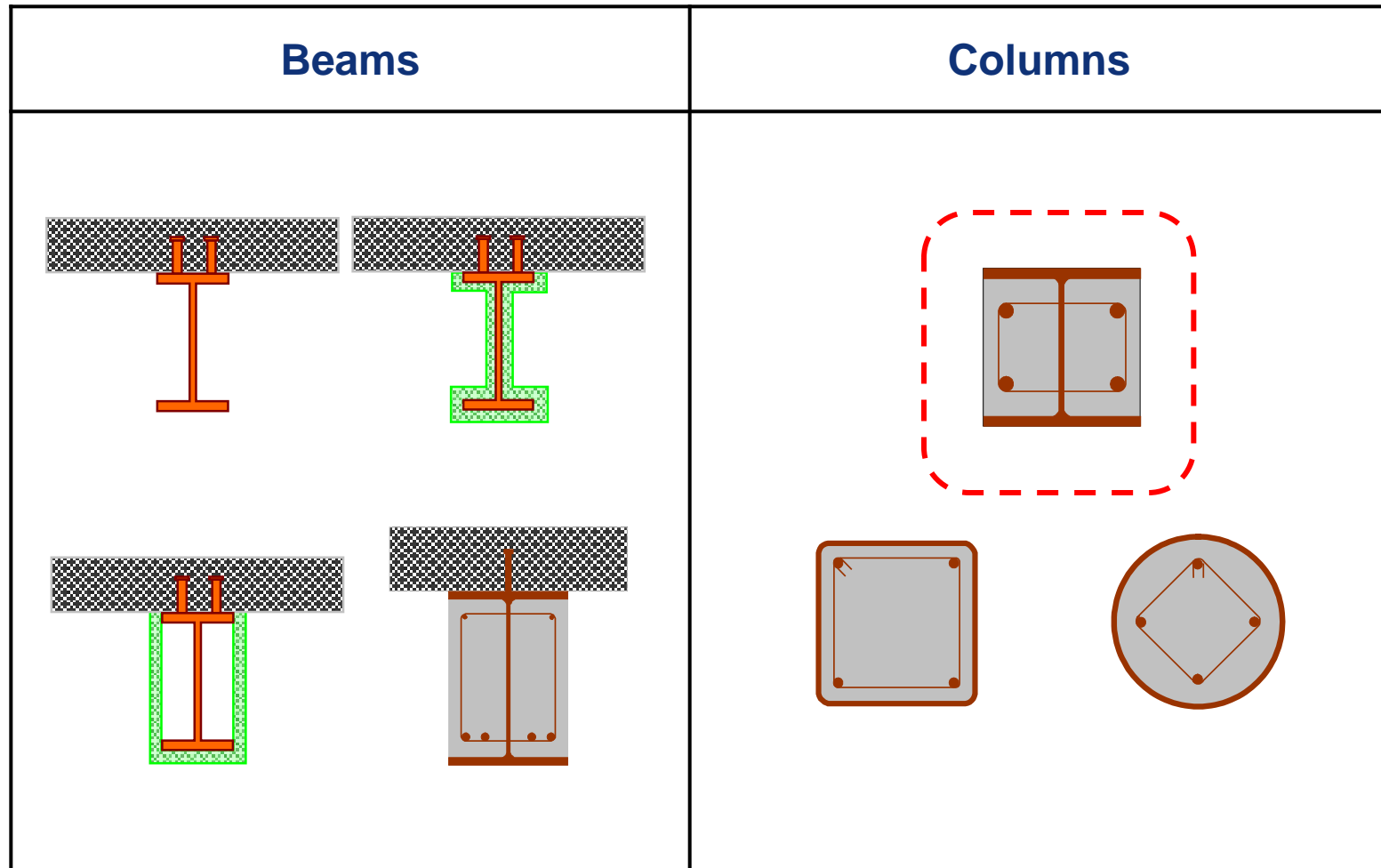

Simple calculation model for composite members

Partially Encased Column

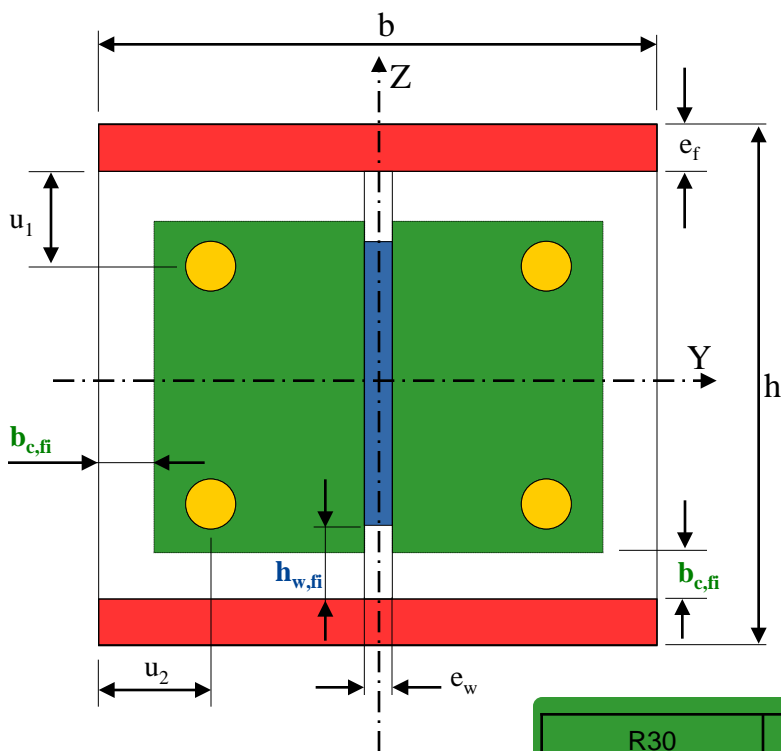

$$f_{amax,w,t} = f_{ay,w,20^{\circ}C} \cdot \sqrt{1 - (0,16H_t / h)}$$

Table G.5: Reduction factor $k_{y,t}$ for the yield point $f_{sy,20^{\circ}C}$ of the reinforcing bars

Standard Fire Resistance \ u[mm]	40	45	50	55	60
R30	1	1	1	1	1
R60	0,789	0,883	0,976	1	1
R90	0,314	0,434	0,572	0,696	0,822
R120	0,170	0,223	0,288	0,367	0,436

Table G.6: Reduction factor $k_{E,t}$ for the modulus of elasticity $E_{s,20^{\circ}C}$ of the reinforcing bars

Standard Fire Resistance \ u[mm]	40	45	50	55	60
R30	0,830	0,865	0,888	0,914	0,935
R60	0,604	0,647	0,689	0,729	0,763
R90	0,193	0,283	0,406	0,522	0,619
R120	0,110	0,128	0,173	0,233	0,285

R30		R60		R90		R120	
A_m/V [m ⁻¹]	$\theta_{c,t}$ [°C]	A_m/V [m ⁻¹]	$\theta_{c,t}$ [°C]	A_m/V [m ⁻¹]	$\theta_{c,t}$ [°C]	A_m/V [m ⁻¹]	$\theta_{c,t}$ [°C]
4	136	4	214	4	256	4	265
23	300	9	300	6	300	5	300
46	400	21	400	13	400	9	400
-	-	50	600	33	600	23	600
-	-	-	-	54	800	38	800
-	-	-	-	-	-	41	900
-	-	-	-	-	-	43	1000

$$\theta_{f,t} = \theta_{0,t} + k_t (A_m / V)$$

Standard Fire Resistance	$\theta_{0,t}$ [°C]	k_t [m°C]
R30	550	9,65
R60	680	9,55
R90	805	6,15
R120	900	4,65

Partially Encased Column

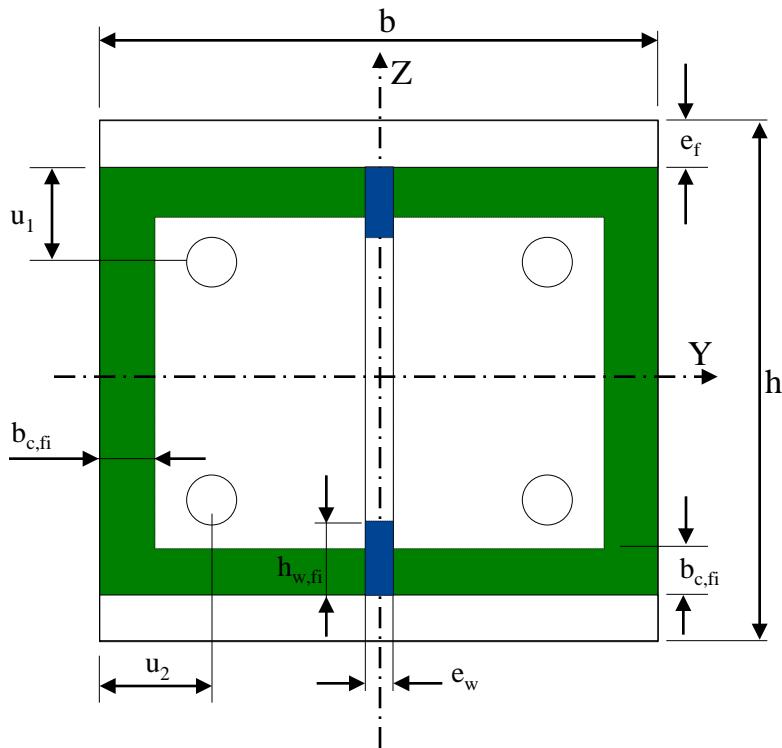

Standard Fire Resistance	$b_{c,fi}$ [mm]
R 30	4,0
R 60	15,0
R 90	$0,5 (A_m/V) + 22,5$
R 120	$2,0 (A_m/V) + 24,0$

$$h_{w,fi} = 0,5(h - 2e_f) \left(1 - \sqrt{1 - 0,16(H_t / h)} \right)$$

where H_t is given in table G.2

Standard Fire Resistance	H_t [mm]
R 30	350
R 60	770
R 90	1100
R 120	1250

Partially Encased Column

$$N_{fi,pl,Rd} = N_{fi,pl,Rd,f} + N_{fi,pl,Rd,w} + N_{fi,pl,Rd,c} + N_{fi,pl,Rd,s}$$

$$(EI)_{fi,eff,z} = \varphi_{f,\theta}(EI)_{fi,f,z} + \varphi_{w,\theta}(EI)_{fi,w,z} + \varphi_{c,\theta}(EI)_{fi,c,z} + \varphi_{s,\theta}(EI)_{fi,s,z}$$

where $\varphi_{i,\theta}$ is a reduction coefficient depending on the effect of thermal stress.

The values of $\varphi_{i,\theta}$ are given in Table G.7

Standard fire resistance	$\varphi_{f,\theta}$	$\varphi_{w,\theta}$	$\varphi_{c,\theta}$	$\varphi_{s,\theta}$
R30	1,0	1,0	0,8	1,0
R60	0,9	1,0	0,8	0,9
R90	0,8	1,0	0,8	0,8
R120	1,0	1,0	0,8	1,0

Table G.7

Buckling curve "c" of EN 1993-1-1

Simple calculation model for composite members

